



# Experiences and recommendations from the ECoDiS project



		<h1>Report</h1>	
ADR.:        Statnett SF Avdeling FoU Nydalen Allé 33 0484 OSLO	Document title: <b>Experiences and recommendations from the ECoDiS project</b>  Authors in alphabetical order: Kjartan Andersland (BKK), Steinar Fines (Tensio/Metior), David Fredriksen (Glitre Nett), Kjetil Furulund (Elvia), Christopher Gebs (Elvia), Ruben Hodnebrug (Glitre Nett), Nargis Hurzuk (Statnett), Maren Istad (SINTEF Energi), Arne Morten Kammen (Tensio), Hans Kristian Hygen Meyer (SINTEF Energi), Santiago Sanchez (SINTEF Energi), Stig Simonsen (Lede), Jon-Martin Storm (NVE) and Svein Morten Strømsnes (BKK).  Contacts: <a href="mailto:maren.istad@sintef.no">maren.istad@sintef.no</a> and <a href="mailto:nargis.hurzuk@statnett.no">nargis.hurzuk@statnett.no</a>		
Classification <b>Open</b>	Project no. <b>77093</b>		
Responsible department <b>RIN- Forskning og Innovasjon</b>	Dokument nummer <b>IFS 4035877</b>	Pages <b>71</b>	
Summary, result: see executive summary on page 4.			

## Contents

<b>Executive summary .....</b>	<b>4</b>
<b>List of abbreviations.....</b>	<b>6</b>
<b>1 Introduction .....</b>	<b>8</b>
<b>2 Digital substations.....</b>	<b>9</b>
<b>3 ECoDiS pilots .....</b>	<b>12</b>
3.1 Elvia pilots .....	12
3.2 Lede pilot .....	14
3.3 Statnett pilot.....	16
3.4 Tensio pilot .....	17
3.5 BKK pilots .....	18
3.6 Digital station in laboratory .....	20
<b>4 ECoDiS experiences and recommendations.....</b>	<b>22</b>
4.1 Technical specification and procurement .....	22
4.2 Engineering and design .....	25
4.3 Standardization .....	29
4.4 Network .....	31
4.5 Time synchronization .....	36
4.6 Monitoring .....	41
4.7 Physical design .....	42
4.8 LPIT .....	43
4.9 Energy metering .....	46
4.10 Condition monitoring of primary components .....	54
4.11 Service design .....	57
4.12 Operation and troubleshooting .....	59
4.13 Local and remote control .....	61
4.14 Competence .....	62
4.15 Retrofit of existing stations.....	63
4.16 Cyber security .....	65
4.17 Regulatory requirements.....	66
4.18 Future challenges .....	68
<b>5 Bibliography.....</b>	<b>70</b>

## Executive summary

This report summarises the experiences and recommendations from the ECoDiS-project (Engineering and Condition Monitoring in Digital Substations - RCN number 296550). The project has had numerous live pilots in the Norwegian grid, activities in a laboratory version of a digital substation in the Norwegian SmartGrid laboratory and research activities at NTNU and SINTEF Energy Research.

The experiences and recommendations of this report are grouped in eighteen topics: technical specification and procurement, engineering and design, standardization, network, time synchronization, monitoring, physical design, LPIT, energy metering, condition monitoring of primary components, service design, operation and troubleshooting, local and remote control, competence, retrofitting of existing stations, cyber security, regulatory requirements and future challenges.

The ECoDiS-project has not covered all topics related to digital substations and within some topics there are no concrete recommendations, but rather “check points” for things to consider when building a digital substation. The recommendations are at different “levels” from high level and to quite specific recommendations. It is important, however, to remember that the pace of change within digital substation technology is rapid, and therefore some of the recommendations might rapidly “expire.” The project hopes the report is useful for all those considering building digital substations. The report also includes information on both the live pilots in the grid and the laboratory set-up of a digital substation.

One important recommendation is to form a Norwegian user group for digital substations, so that the sharing of experiences and the making of best practices can continue after the ECoDiS-project. Competence is an important topic and one chapter in the report is dedicated to experiences and recommendations related to this, in short there is a need for company specific strategies for building competence and the use of laboratory testing in relation to digital substation.

Some high level recommendations from the report are listed below:

- Make detailed technical specifications and commercial contract documents describing all relevant parts of the procurement. The contract's technical requirements specification must be based on the latest/newer versions of international standards from IEC / IEEE and similar. The technical specifications should cover all topics discussed in this report. A common Norwegian specification for digital substations should be made and shared in the energy sector as a basis for company specific specifications.
- DSO/TSOs in Norway should build in house competence to develop the IEC 61850 engineering modelling in cooperation with other DSO/TSOs in Europe. In the long term the files generated from such IEC 61850 modelling tools will be the vital part of substation documentation.
- Use the latest / newer versions of IEC 61850 series (ED 2.1).
- PRP has been the preferred network protocol choice of most pilots in the ECoDiS-project. PRP is the recommended choice, although at the cost of more hardware.
- Monitor abnormal conditions on networks to try to detect errors/problems, like a "health check" of the equipment.

- Different vendors are developing the tools to monitor both sample values and GOOSE in the substation. DSO/TSO should try to use them and establish the standard for monitoring these types of signals.
- Experience from ECoDiS suggests that TSO/DSOs should have ownership of networks and time synchronization. To have enough competence and experience, the same set-up should be used in as many substations as possible.
- Requirements and calibration routines for energy metering in digital substations must be developed. It is considered an advantage if these are prepared jointly with other countries and made applicable to several countries or regions.
- The solutions for metering offered in today's market cannot be recommended for use for settlement. This is mostly since the solution has no documented measurement capability and cannot be verified on site.
- It is recommended to carefully plan the infrastructure for collecting, distributing, and using condition monitoring data in the organization at an early stage of a digital substation project. Data streams/networks for asset management should be completely separated from the PACS networks. It is also recommended to develop better techniques for utilizing and acting upon the condition monitoring data.
- Acquire testing equipment and get familiar with the test equipment in cooperation with the vendor. It is important to be able to perform tests and therefore essential to build internal competence.
- Cybersecurity: Digital substations should be designed with the use of both the IEC 62443-series and the IEC 62531-series.

## List of abbreviations

AIS	– Air Insulated Switchgear
BMCA	– Best Master Clock Algorithm
CID	– Configured IED description
CT	– Current Transformers
DRTS	– Digital Real Time Simulator
DS	– Digital Substation
DSAS	– Digital Substation Automation Systems
DSO	– Distribution System Operator
ECoDiS	– Engineering and Condition monitoring in Digital Substations
EMP	– Electro Magnetic Pulse
EVT	– Electronic Voltage Transformer
FLDS	– Flexible Laboratory Digital Substation
FOCS	– Fiber Optic Current Sensors
GIS	– Gas Insulated Switchgear
GMC	– Grand Master Clock
GOOSE	– Generic Object-Oriented Substation Event
GPS	– Global Positioning System
HES	– Head End System
HMI	– Human Machine Interface
HSR	– High-Availability Seamless Redundancy
HV	– High voltage
IEC	– International Electrotechnical Commission
IED	– Intelligent Electronic Devices
IT	– Instrument Transformer
LCC	– Local Control Cabinet
LPCT	– Low Power Current Transformer
LPIT	– Low Power Instrument Transformer
LPVT	– Low Power Voltage Transformer
LV	– Low Voltage
MMS	– Multimedia Messaging Service
MU	– Merging Unit
NSGL	– National SmartGrid Laboratory
NTP	– Network Time Protocol
OCT	– Optical Current Transformer
OEM	– Original Equipment Manufacturer
OT	– Operational Technology
PACS	– Protection, Automation and Control System
PD	– Partial Discharge
PMU	– Phasor Measurement Unit
PQ	– Power Quality
PRP	– Parallel Redundancy Protocol

PSU	– Power Supply Unit
PTP	– Precision Time Protocol
RBAC	– Role based Access Control
RSTP	– Rapid Spanning Tree Protocol
RTU	– Remote Terminal Unit
SAMU	– Stand-Alone Merging Unit
SAS	– Substation Automation Systems
SAT	– Site Acceptance Test
SCD	– Substation Configuration Description
SCL	– Substation Configuration Language
SDN	– Software Defined Networking
SFP	– Small Formfactor Pluggable
SIT	– System Integration Testing
SNMP	– Simple Network Management Protocol
SSD	– System Specification Description
SV	– Sample Values
TRL	– Technology Readiness Level
TSO	– Transmission System Operator
VLAN	– Virtual Local Area Network
VT	– Voltage Transformers

## 1 Introduction

This document is written in work package 6 (WP6) of the ECoDiS R&D-project (*Engineering and Condition Monitoring in Digital Substations* – funded by the Research Council of Norway under grant agreement no. 296550). This document fulfils the following subgoal of the ECoDiS-project: *Provide recommendations and strategies for implementation of DS (digital substation) for TSO and DSOs (WP6)*. WP6 should (among other things): *Provide recommendations for engineering, LPIT and condition monitoring in digital substations. Summarize best practices. Investigate future possible designs and solutions in workshops.*

This document presents experiences and recommendations from the ECoDiS-pilots (live pilot stations and laboratory pilot), numerous workshops and discussions within the project group. There are of course topics related to digital substations where there is *not* enough experience to provide recommendations, hence not every topic related to digital substation is covered. For some topics experiences are summarized, but no concrete recommendations provided. The aim is to have as concrete recommendations as possible for the topics where ECoDiS has experiences and opinions to provide recommendations. The recommendations are mostly related to the planning and engineering phase of DS, where there is gained most experience. Some of the recommendations might become obsolete as more experience is made and/or more mature products and services are available.

The recommendations are provided for different topics, but some recommendations are relevant under several topics. Some recommendations are based on experiences from several pilots, while others are based on few experiences, hence there is a difference in the basis for the recommendations. If there are recommendations relevant on one particular voltage level or different recommendations on the same topics due to different company policies, this is commented in the text. Some recommendations are specific for Norway/Nordics due to harsh weather conditions and/or specific regulatory requirements.

This report is based on state of art for process bus as it is right now. Development related to the process bus are happening very fast. It is likely that the substation technology will develop in the direction of further virtualisation of functions. ICT and OT competence and not the least reliability and cyber security will be the important focus areas. Many functions, like protection and control system, will to larger degree probably be operated and managed as IT systems with opportunities to automate testing. This is expected to facilitate higher digital security and also simpler and far more effective regime for upgrading. Different vendors and even some DSO/TSO are already working towards this virtual approach with centralized substation computer. The initiatives are also relevant for energy metering. Some prototypes will be available for testing in a near future. The pilots being tested as a part of ECoDiS are necessary intermediate step towards the future protection and control system.

This report first provides some general information on digital substations and the potential benefits of such substations, then the pilots of ECoDiS is presented, followed by the experiences and recommendations of the project. A list of abbreviations and an executive summary is provided at the beginning of the report.



## 2 Digital substations

Digitalization of substations have a large impact on all parts of the life cycle of a substation, ranging from design, engineering, installation, testing, operation, renewal, maintenance to dismantling. With modern Intelligent Electronic Devices (IEDs), communication between units is facilitated and multiple control and protection functionalities can be integrated into single devices, resulting in more compact substations. Hardwired copper point-to-point connections can be replaced with a digital network using IEC 61850. With a substantially reduced amount of copper-wiring and consequently potential for simplified installation and testing procedures, the costs associated with building new substations can, **in the future**, be significantly reduced. In theory, digital infrastructure is just a network, and an IED running code. It requires more attention to building one bay, but it has great potential for scaling to more bays. Today, this is not the case, as the integrations are not good enough between different vendors and manual changes are necessary. Fault localisation is today time consuming, but as more experience is gained this will change. Installation of new compact components like Low Power Instrument Transformers (LPITs) and more sensors creates an opportunity for more accurate measurements available for real-time monitoring and analysis. In addition, the large amount of data can today easily be stored, paving the way for data analysis for prediction, correlation, and pattern recognition purposes. Figure 1 illustrates some of the benefits of digital substations. Digital substations (DS) are also safer for personnel during installation and operation as conventional instrument transformers are replaced by LPITs which leads to elimination of current and voltage circuits, and the need to have personnel on site can be reduced thanks to availability of remote data. To summarize, digital substations can potentially be **smaller, smarter, and safer.**

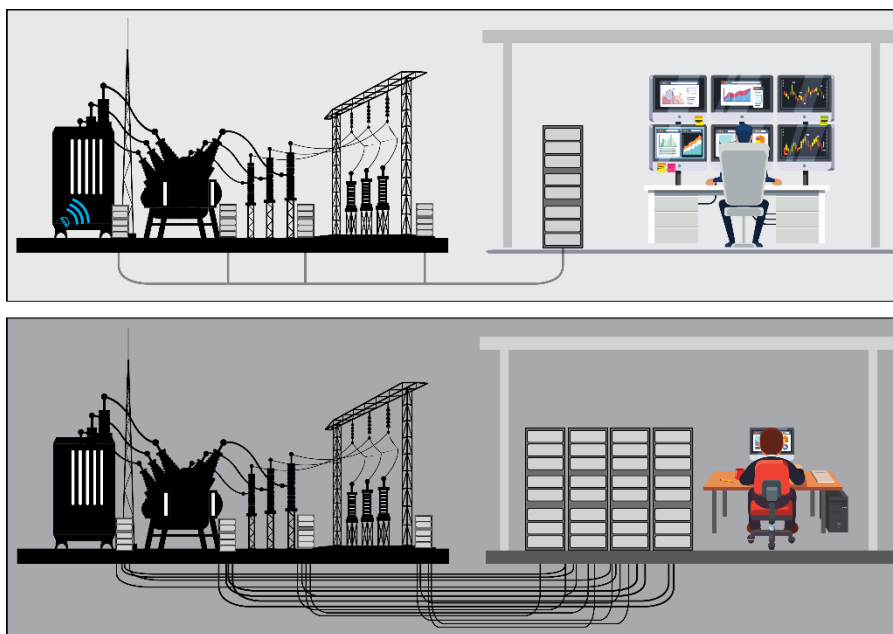

*Figure 1 Digital substation (on top) with less wiring, integrated units, more sensors, and more data to analyse compared to the conventional substation (at the bottom).*

For Norwegian TSO/DSOs, digital substations represent a paradigm shift from point-to-point connected components, conventional protection devices and many manual tasks, to

digitalization of signal transfer, monitoring and analysis. In addition, it can represent a considerable increase in available high-resolution measurements. Indeed, with increased complexity and faster changes of operational conditions in the power networks due to a higher share of renewables and change of load patterns, there is a strong need for more real-time monitoring of the power system.

The **potential** value or benefits from digital substations ranges from personnel safety and reduced cost of installation to improved security of supply. A digital substation can be smaller, smarter, and safer compared to a conventional substation. Other potential benefits are provided in the list below:

### **1. Improve the safety during installation and operation:**

Conventional Current and Voltage transformers (CTs and VTs) carry an inherent safety and environmental risk as they are filled with oil or gas (explosions and fires); they are large and require copper wire connections across the substation to connect to the secondary equipment. There is also an inherent danger posed by the open CT circuit. The risks associated with commissioning of VT's are well known and several cases of explosions has occurred in the past. Measures to prevent explosions due to faulty instalment include long and tedious checklists and procedures during commissioning of VT's. Using LPIT, the safety of commissioning personnel will be improved, and commissioning time will be greatly reduced due to safe and simple plug-and-play solutions implemented in DS. Elvia has experienced breakdown of 72 VTs due to ferro-resonance in 1988, which could have caused personnel injury or death. LPITs eliminate all these risks. As more data will be available remotely, the need for personnel to travel to the remote substations (sometimes in harsh weather conditions) will be reduced or may be eliminated.

### **2. Reduced use of space**

One general advantage of GIS is the reduction of land use, compared to AIS. The use of LPIT in GIS makes them even smaller which is particularly important in city areas with limited space and the substation where reuse of buildings might be necessary. The increased focus on limiting land use, in general, might increase the use of GIS in the future, as alternatives to SF<sub>6</sub> are available making the environmental footprint of GIS acceptable. GIS can also be placed in containers and be mobile back-ups in cases of planned work or failures. DS also reduces the number of control cables hence fewer cable trays and wall penetrations are necessary. The control room is also smaller, see Figure 1, hence the space required for AIS is also reduced. The size of the control room can be reduced due to options to combine many protection and control functions in the same component. In case of reinvestments and expansions of stations (brownfield), by building control facilities with process buses, we can avoid expansions of the control room - which will shorten the development time considerably. The distance between the primary switchgear and the control room can be much longer than today so that we do not need to build the control facilities near the switchgear. Significant reduction of copper cables between primary components and control rooms, when switching to an infrastructure in the facilities consisting of a data network realized on fibre (process bus).

### **3. Flexibility of substation**

The digital substation is flexible and new concepts for i.e. protection can be implemented. Disconnections can be faster, hence reducing the wear of components. Components can be redundant for each other, i.e. the protection function from one IED can be used as back-up for another IED, and the grand master clock source can be selected from different devices on the process bus, hence enhancing the flexibility and potentially reduce the number of components.

#### **4. Reduced time and cost for testing and commissioning:**

Performing parts of the SAT (site acceptance test) in the lab will reduce time and costs. Site testing will be easier with the installation of LPITs. For instance, there will be no need to test the burden of the secondary current circuit. In the future testing can be more automated. Moreover, it will be possible to reduce the installation time by around 20% because many of the tests can be carried out in the factory and reused. The disconnection times will be reduced because the new control system can be established before the old system is replaced. This will reduce the disconnection time from the normal 4 weeks to approx. 1 week.

#### **5. Increase security of supply through optimized asset management:**

New measurements together with data analysis could lead to advanced monitoring of primary equipment (transformers, switchgears, lines, and cables, etc.) to enable state-of-the-art concepts like condition-based and predictive maintenance using digital twins. This could on the one hand reduce maintenance cost (as maintenance is only done when it is necessary) and at the same time increase total availability (as equipment outages could be detected early). Reinvestments can also be optimized based on condition monitoring, challenging today's practice where age of component is an important criterion for reinvestment.

#### **6. Improved operational performance through real-time data:**

Since primary equipment can be monitored in real time, its utilization can be maximized by operating it closer to its physical limit, i.e. temperature restrictions. Real-time information such as environmental or weather conditions together with grid analysis would allow to fully utilize existing primary equipment. Digital twins for i.e. transformers can be developed and continuously learn and update itself from the multiple sources to represent its near real-time status. Also, digital twins can be used to predict different outcomes, i.e. temperature or current, based on variable data from different sensors.

#### **7. Improve TSO/DSO interaction and shared ownership:**

Substation digitalization makes TSO and DSO cooperation easier, but still data exchange and establishment of best practices for DS in Norway must be discussed. Issues related to digitalization of substations with shared ownership must be investigated further.

#### **8. Increase the value of the Norwegian digital substations:**

Testing of climatic endurance for components is a practical benefit from this project and aid the adjustment of DS for Norwegian climatic conditions and the regulatory requirements.

Digital substation is today marketed and sold by vendors as an "off the shelf" product. But both Norwegian TSO/DSOs and the research community strongly believed in 2019 when ECoDiS started and **now in 2024**, that more knowledge and competence is needed prior to a full implementation of digital substations, in order to maintain security-of-supply on a short term and ensure both value creation and security-of-supply on a long term. The access to more accurate data, both real-time and historical, improves monitoring of state and technical condition of components in the substation. Consequently, better operational, maintenance and reinvestment decisions can be made, and costs can be reduced. But, prior to harvesting these benefits of digital substations, there are challenges that need to be investigated, i.e. availability and quality (life expectancy and ability to withstand the Nordic climate) of sensors, cybersecurity, interoperability, ability of IEC 61850 to support new functionalities – and not the least, testing condition models using digital twins. ECoDiS has investigated these challenges in pilots and the platform in the National Smart Grid Laboratory. The pilots, experiences, and recommendations from ECoDiS is provided in chapter 3 and 4.

### 3 ECoDiS pilots

In this chapter a brief description of all ECoDiS pilots is provided. The recommendations in this report are based on experiences from these pilots. In Figure 2 the pilots of ECoDiS can be seen. In addition, Glitre Nett has conducted rebuilds of existing substations, which has provided interesting experiences that have been included in the recommendations provided in the report. BKK has built two additional DS which is also presented below. The different pilots are briefly described in the sub-chapters below.

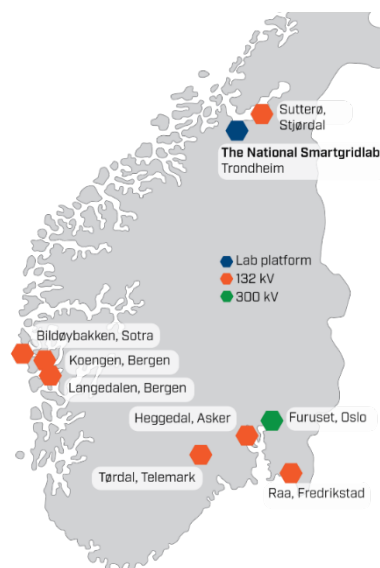

Figure 2 Map of ECoDiS-pilots.

#### 3.1 Elvia pilots

Elvia has contributed with two different pilots within the ECoDiS project. A brief summary of the two pilots, which have quite different technological solutions, is described here. Two papers were published about the pilots [1] and [2].

##### 3.1.1 Heggedal

In Heggedal substation, Elvia has upgraded/built a substation based on IEC61850-9-2(LE) and IEC61869-1 (2007), IEC61869-6 (2016), IEC60044-7, and -8, which consists of:

- 22kV air insulated breakers, 19 bays duplex
- LPIT (Low power instrument transformers) for 22kV
- 3 transformers
- 132kV SF<sub>6</sub> free GIS HV breaker with LPIT and MU
- Centralized backup protection for 22kV based on SV.
- PDWatch (Partial Discharge) /BWatch: GIS watch for system monitoring of GIS breaker.
- Transformer monitoring
- Multi-vendor project for testing interoperability
- Helinks SSD-file design top/down engineering



Figure 3 Heggedal substation.

As the list of the equipment describes, it is clearly seen that this is a comprehensive pilot for a digital substation based on older IEC standards for digital substations. At the time of the tender, the available equipment had not been updated to comply with the most recent standards. It has been interesting to experience a slightly older, but more mature integration of a digital substation. The older standard has some limitations, but after one year of operation Heggedal has not experienced any issues after commissioning. There are a lot of new areas to build competence and gain experience even with a slightly outdated framework for a digital substation.

### 3.1.2 Raa

In Raa substation, Elvia has refurbished a large substation with modernization of the control system for 132/47/18/11kV transformer and bays (AIS) and some test facilities for Digital Substation which consist of:

- Mix of MU, SAMU, and conventional measurements
- 132kV consist of two transformers 132/47/11 kV, two transformers 132/18kV, bus coupler and two lines. The busbar is mirrored across the bus coupler. One side (including the bus coupler) use optical current transformers and electronic voltage transformers. Conventional measurements on remaining bays and for comparison on busbar and line in the digital part. Busbar protection and transformer differential protection use SV from SAMUs on conventional 132kV lines and transformer bays.
- OCT and MU based on 61850-9.2 edition 2 amendment 1, and IEC 61869-9
  - 2 x EVT/OCT
  - 2 OCT
- Time synchronization based on GPS distributed with PTPv2 using IEEE C37.238 (2017) profile.
- Comparison of conventional IT and LPIT
- Network design with use of PRP for process bus and RSTP for station bus.
- MU and BCU placed in outdoor cabinets.
- protection relays and switches, are placed in the control room.
- Top/down engineering with Helinks. Helinks was used to create an SSD-file for the project tender.



Figure 4 Raa Substation.

Raa is based on the most recent available standards for digital substations. The substation is a mix of conventional and digital solutions. During engineering and commissioning the new standards has shown great potential. Including flexible streams and GMC ID on SVs. PTP is more uniformly implemented with all devices supporting the same profile. In the first year of operation Elvia has experienced multiple issues with MUs and time sync, but faults have always been cleared correctly.

### 3.2 Lede pilot

Tørdal substation is a substation in the municipality of Drangedal in Telemark County. The substation is connected to 132 kV grid in Telemark with one 132/24 kV transformer and room for one additional transformer. The station is mainly built due to increased power generation. The power generation is fed through the 24 kV switchgear. In Figure 5 a 3D model of the station is shown. The station was energized by 1st of May 2020. The transformer is equipped with a digital twin (Core sense, Core tech and Transformer Analyzer) from Hitachi to optimize monitoring and operation. The system can provide real-time measurements of oil quality and other relevant measurements from the transformer. The main goal for the monitoring and operation technology is to minimize maintenance cost while maximizing the utilization of components. The transformer was reused and moved from another substation, thus all new sensors, such as the Core sense, had to be retrofitted.



Figure 5 Tørdal Substation.

All connections are digitized as close as possible to the source. The control system is built with process- and station bus according to IEC61850. In Figure 6 a simplified sketch of the topology is shown.

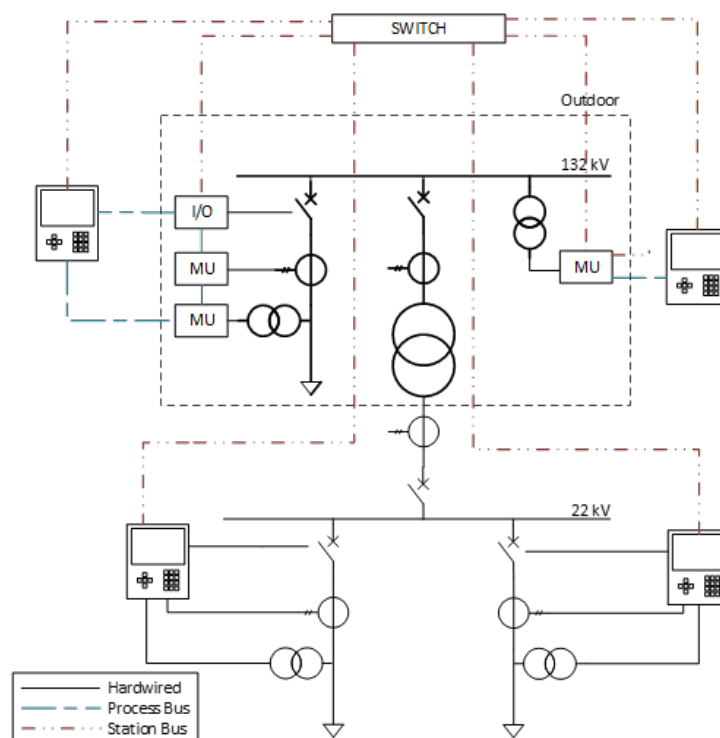

Figure 6 Simplified topology for Tørdal Substation

The measurements from the 132 kV instrument transformers are converted from analog to digital in merging units, which are then connected via a process bus to the IEDs, which in turn is connected to the station bus. The measurements from 22 kV instrument transformers are connected directly to the IEDs which are connected to the station bus. All logic and interlockings are placed in the IEDs.

The station has been in service for almost 4 years and during this time there has been few incidents and issues. However there have been some on-going issues where the signals and measurements from the substation have not been transferred to the central control system. This is both due to on-site connectivity and architectural limitations.

The substation building was planned and contracted at an early stage in the project, and the decision to build a digital control system was made at a later stage. Thus, the reduced footprint of the digital control system was not utilized to reduce the size of the control room.

In Figure 8 and Figure 7 the difference between footprint of the “hybrid control system” and the digital control system is illustrated.

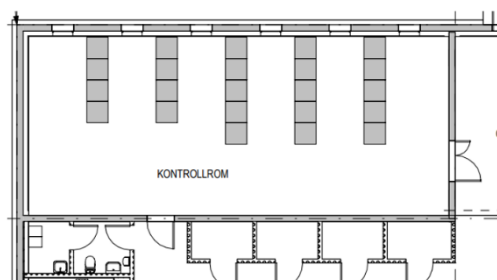

*Figure 8 Control room with hybrid control system.*

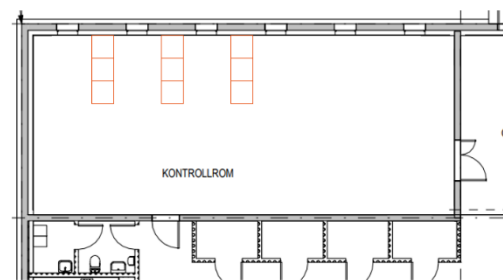

*Figure 8 Control room with digital control system.*

### 3.3 Statnett pilot

Statnett has implemented a pilot project, at Furuset, based on IEC 61850-9-2-LE that has been in operation since September 2017. The Digital Substation pilot includes protection and control for two 300 kV transmission lines in the same IED hardware. The process bus-based DSAS was installed in a live 300kV line bay in parallel with an already existing SAS. There are IEDs from three vendors – ABB, Siemens, and Sprecher – in addition to LPIT and merging units from Arteche. The pilot is an AIS. A simplified topology of the pilot installation is shown in Figure 9.

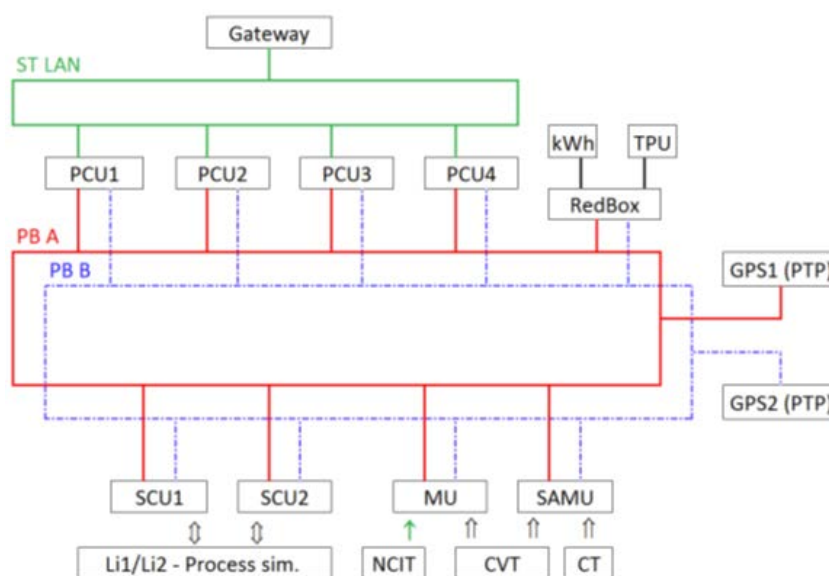

Figure 9 Simplified topology of the Statnett pilot.

The project aimed to set-up a multi-vendor system in order to be able to compare technologies as well as prove the interoperability of the necessary technologies for DSAS, e.g. the impact of using LPITs and Merging Units in protection algorithms from different vendors. Although the pilot installation has been in operation since September 2017, it has not experienced any severe high voltage fault. However, there has been a few situations where it has been verified that the behaviour of the protection IEDs based on the process bus in most of the cases are aligned with those based on hard wired connections in the parallel system.

Statnett has started working on building their first substation with a process bus. In addition, there is a desire to use LPIT in parts of the station. Currently, the technological maturity of LPIT is not sufficient for metering purposes for them to fully replace conventional instrument transformers. Technology qualification of process bus and LPIT must be seen as qualification of systems, not as individual components and will be on a green field GIS system. Process bus and digital measuring equipment are new technologies in Statnett and will require a significant increase in competence, both on the project side, but also among those who will operate and manage the facilities. Publications about the pilot can be found here [3] and [4].



### 3.4 Tensio pilot

**Sutterø substation** in Stjørdal has been Tensio' s pilot in ECoDiS:



- Hitachi Energy Norway AS (former ABB and Hitachi ABB)
- 132 kV SF<sub>6</sub> free GIS, 5 bays (1 bay operated on 66 kV)
- 22 kV air insulated breakers, 16 bays duplex
- 3 transformers
- LPIT on all bays, except 22 kV transformer bays due to energy metering.
- One digital energy meter for testing
- All IED's placed inn LCC.
- PRP for 132/66 kV IED's, HSR for 22 kV
- Goose interlockings between bays.
- Central GPS-clock for the station network
- All network components (switches etc) are vendors' product.

The vendor has designed and delivered all equipment in the station network. The purpose was to minimize the risk of interoperability at the time the order was put in place. The station was energized in October 2023. The test period was delayed several times because of some time-consuming testing on site. Some of this can be ascribed to new technologies and probably some lack of wide experience for the vendor, as well as the customer.

### 3.5 BKK pilots

BKK has contributed with five different pilots within the ECoDiS project. A brief summary of the pilots is provided below. For location, see Figure 10. Knarvik and Blomøy was not built when BKK entered the ECoDiS-project and is therefore not in the map in Figure 2.



Figure 10 The five BKK pilots.

#### Langedalen:

- ABB / Hitachi
- Norway's first digital station in operation.
- 132kV AIS
- Operational in 2018
- Two feeders, bus coupler and tie connections
- FOCS (polarized light) and MUs in combination with traditional current and voltage measurement
- Differential protection /GPS sync.
- Topology: HSR ring with Global PTP due to line differential protection
- Digital kWh metering (for testing)
- High quality field cabinets, EMP version, with extra focus on temperature and humidity due to electronic components
- Process bus switch: Vendor's product.
- Lab (design) early in project.

#### Koengen:

- Siemens Energy
- 132kV GIS
- Operational in 2020

- Two transformers
- One feeder and busbar
- First BlueGis in the world
- LPIT (mV, mA)
- Topology: PRP, where PTP is rebuilt from global to local
- No kWh-metering
- Differential protection with its own GPS clock
- Process bus switch: Vendor's product.
- IEDs are housed in LCC cabinets, with the exception of busbar protection.

**Bildøybakken:**

- Siemens Energy
- 132kV GIS
- Operational in 2021
- One transformer
- Four feeders, bus coupler and busbars
- LPIT (mV, mA)
- Topology: PRP, where PTP is rebuilt from global to local.
- No kWh metering
- Differential protection with its own GPS clock
- Process bus switch: Vendor's product.
- IEDs are housed in LCC cabinets, apart from some transformer IED's.

**Knarvik:**

- Siemens Energy
- 132kV GIS
- Operational in 2023
- Two transformers
- Two feeders, bus coupler and busbars
- LPIT (mV, mA)
- Topology: HSR ring, where PTP is local
- Digital kWh metering (for testing)
- Vendor redbox, no process bus switch
- IEDs are housed in LCC cabinets, except for one IED.

**Blomøy:**

- Siemens Energy
- 132kV GIS
- Operational in 2024
- Three transformers
- Three feeders, bus coupler and busbars
- LPIT (mV, mA)
- Topology: HSR ring, where PTP is local.
- Digital kWh metering (for testing)
- Differential protection with its own GPS clock
- Vendor redbox, no process bus switch
- IEDs are housed in LCC cabinets, except for one IED

### 3.6 Digital station in laboratory

SINTEF Energi has developed a flexible laboratory digital substation (FLDS) in the Norwegian National Smart Grid Laboratory (NSGL), see Figure 11. The FLDS can be used for simulating an environment of multiple voltage levels. Hence, it is possible to run tests based on process bus communications for simulated values in medium voltage distribution grids and high voltage transmission grids. The laboratory has a digital real time simulator (DRTS) from the vendor OPAL-RT<sup>1</sup> with synchronization based on GPS. The DRTS has license for IEC 61850 standard, with SV (IEC 61850-9 based on substation configuration language and IEC61850-9-2LE sampled values). OPAL-RT supports IEC 61850-9-2LE Sampled Values, as well as Samples Values based on a Substation Configuration Language (SCL) file (IEC 61869-9). It is a flexible system that supports multiple implementations of the SV protocol, GOOSE and GPS synchronization plus Precision Time Protocol (PTP). It is possible to stream sampled values at 80 samples per cycle or 256 samples per cycle. Therefore, the DRTS can be used as a MU or for subscribing to another MU.

The DRTS can be configured to simulate electromagnetic system models, for example a power system line model and stream the current and voltage measurements emulating multiple merging unit (MU) devices. Besides, the laboratory has two MUs from different vendors that can replicate traffic in a process bus of a digital substation based on analogue measurements of voltage and current. Two IEDs can be configured with different protection functions to test protection schemes. MUs and IEDs can be configured with their configuration software for example DIGSI-5 for Siemens devices and PCM600 for ABB IEDs. Hence, the users can reconfigure the devices to run multiple use cases.



Figure 11 NSGL flexible digital substation equipment. (Left) DRTS from OPAL-RT and optic fibre rack. (Right) Multiple vendor MUs, IEDs, GPS clock and communication switches.

<sup>1</sup> <https://www.opal-rt.com/software-communication-protocols/iec-61850-9-2-sampled-values/>

The communication network enables the flexibility for configuring and testing different scenarios. Figure 12 shows the configuration of the flexible digital substation at the NSGL in Trondheim. Black connections describe the use of wide area communication protocols such as IEC 60870-5-104. Blue line connections describe the communication network that can use process bus traffic with frames based on IEC 61850, for example GOOSE. The network can be connected as one network with the configuration of a switch that uses software defined networking (SDN). A Linux server can be connected to multiple parts of the communication network of the laboratory. More information can be found here, [5], [6] and [7].

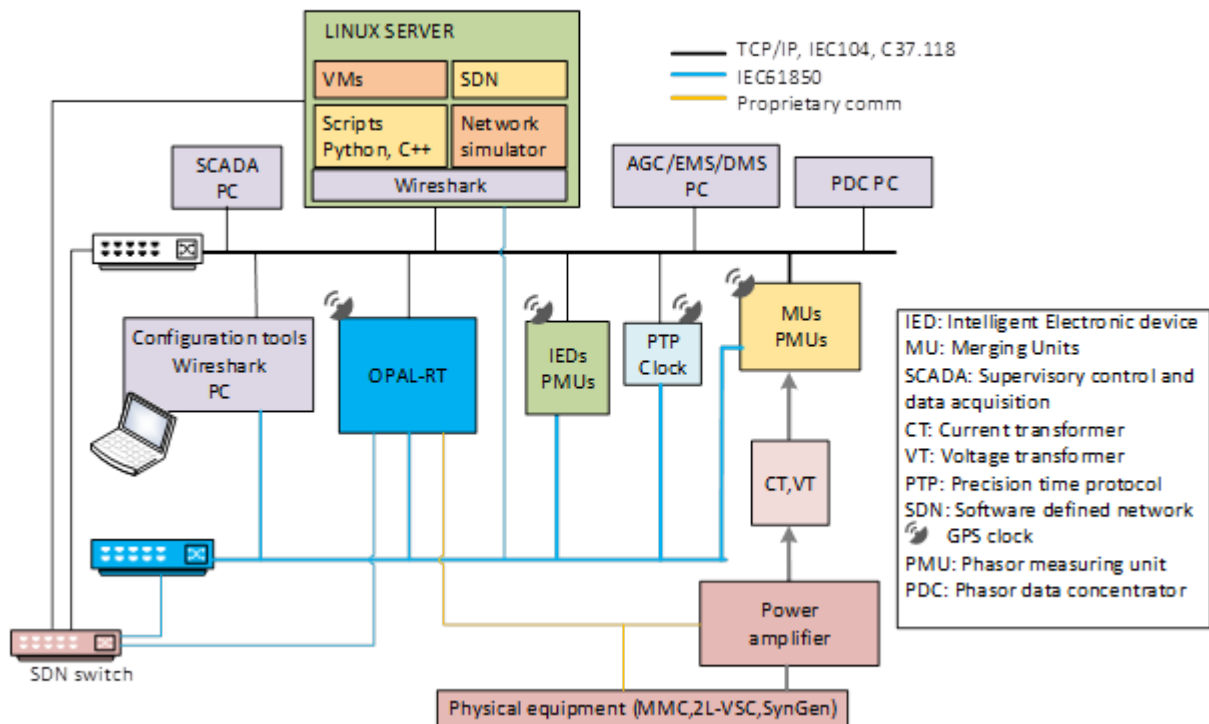

Figure 12 Communications connection for NSGL's flexible digital substation.

## 4 ECoDiS experiences and recommendations

In this chapter experiences and recommendations are provided for different topics related to digital substations. The document does not cover all topics related to digital substations but covers the topics where ECoDiS has had experiences and can provide recommendations based on these experiences. For some topics, the project does not have a concrete recommendation, but rather experiences of what has worked or not and this can be useful tips for others.

One important recommendation is to form a Norwegian user group for digital substations, so that the sharing of experiences and the making of best practices can continue after the ECoDiS-project.

### 4.1 Technical specification and procurement

Based on the experiences from the pilots in the ECoDiS project it is strongly recommended to have very detailed technical specifications and commercial contract documents describing all relevant parts of the procurement. The contract's technical requirements specification must be based on the latest/newer versions of international standards from IEC / IEEE and similar. The technical specifications should cover all topics discussed in this report. A common Norwegian specification for digital substations should be made and shared in the energy sector as a basis for company specific specifications.

It is recommended to use standardised contract documents, as for instance Kolemo 3.2<sup>2</sup>. This contract is developed for use in the energy sector for acquisitions with many interfaces between different vendors. The contract states terms for technical responsibility, payment, progress and milestones, takeover, interfaces, responsibility, change management, conflict management and so on. This is crucial where several vendors of for instance power transformers, GIS breakers, HV/MV equipment, measuring systems, control systems and building facilities are parts in the contracts.

---

<sup>2</sup> [Link to Kolemo 3.2](#)

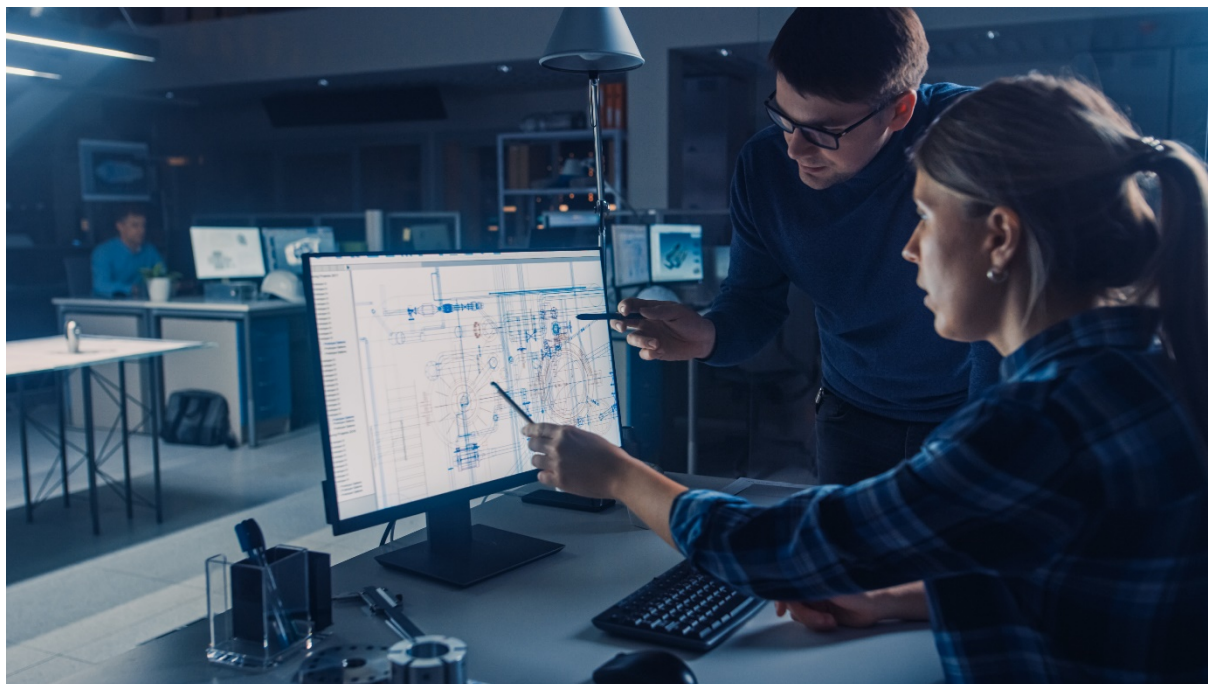

Source: Shutterstock

Other, more specific recommendations related to technical specification and procurements are provided below.

- Quality flags are indicators of the quality of the data. In one pilot a quality flag where validity was questionable appeared and some IEDs accepted the data, while others blocked the data based on the same quality flag.

It is recommended to specify the reaction of IEDs to different quality flags to ensure that they have the desired response.

Response to quality flags is related to technical requirements and interoperability between different assets. In the technical specification one can refer to standards, but it can be that the different vendors interpret the standards differently and different vendors might use different standards or versions of the standards. SAMUs used for 22kV in one pilot supported test mode, but simulation was only supported for GOOSE, and not for SVs. This was not obvious in the initial stages and made testing during operation difficult. Some IEDs response could be adjusted based on user needs, but all MUs used in at least two pilots only use “valid/invalid.” If “questionable” occurred it was not interpreted by the MU.

- Protection and metering use SVs from the same MU, but the SVs are published as two separate streams. The measurement chain is specified to class 0.2S. 0.2S requires the MU to compensate for external factors such as temperature. It would be beneficial if the MU could indicate deviations from 0.2s as questionable (+inaccurate), not invalid. As this should not really affect most protection functions but might be relevant for metering.
- An experience from one pilot was that one SAMU required 24VAC auxiliary voltage and needed an adapter, as all the other equipment had auxiliary voltage of 110VDC.

It is recommended to specify the auxiliary voltage requirement for equipment.

- Redundant power supply to components must be considered as systems are more dependent on each other. It is challenging to see all the interconnections in a DS.
- Remote access to equipment must be specified. The periodic testing of conventional stations will be replaced by checks of measurements and logs in IEDs in a secure manner.
- The decision on topology of the digital substation must be made in the specification. Vendor solutions with complex topology should be avoided as it increases the complexity in the operational phase. The maturity of the vendor should be evaluated as temporary equipment/solutions that are phased out will create problems related to spare parts and competence at a later stage. The maturity of different vendor products can be difficult to assess, but experiences from other DSO/TSOs will be valuable.
- Topology is created per station early in projects, and new elements must be assessed in particular, with a view to whether there is a need for lab tests or studies. It may take longer in the planning phase as a result, but if it is omitted, there may be greater consequences later in the project. Topology must consider the need for connection of test equipment, e.g. PC or Omicron.
- One party must have the responsibility for interoperability (integration process/coordination) in a substation. If you choose to deliver your own network switches, it can be challenging to get a vendor to take responsibility for interoperability. It is important to clarify the responsibility for this. Delivering your own switches can be important for security, but the pros and cons must be evaluated.
- Consider equipment replacement and station expansions when planning a digital substation and try to make both replacements and expansions as easy as possible with your current knowledge. Some equipment, like switches, in digital substations needs more rapid replacement than in conventional stations, hence it can be worth extra consideration.
- Topics such as operational testing of protective functions, switching without interlocking/emergency switching, must be considered. The amount of local and remote signals, degree of redundancy and clock function are also important aspects to investigate.
- FAT and SAT plans/content should be made earlier than has been the standard for substation projects.
- The stock of spare parts may not be sufficient, due to new types of equipment or the fact that there are versions that do not fit in with the chosen equipment in operation.
- LPIT has larger measuring range compared to conventional instrument transformers, but different vendors make different choices which affects the measuring range; hence it is important to specify the desired measuring range and check that the vendor can deliver this without too high inaccuracy. It is important to make specifications related to LPIT, as there are still different choices of technology that can be made, and these have different pros and cons.
- The range of the most likely failure currents must be specified as this is decisive for the choice of technology.
- There must be requirements for installation in order to avoid faulty installation and/or pollution. This is a generic requirement, but especially for DS it is important to have requirements for accuracy of fibre splicing.



- The cable prior to digitalization, when analogue signals (mV/mA) are transported from LPIT to digitalisation unit, i.e. in control room, cannot be too long and not be situated anywhere due to susceptibility of mV/mA to noise.
- In one ECoDiS-pilot, the station building was planned prior to the decision of building a DS, hence the building was too large, and the value of reduced building size was not harvested.
- It is an option to choose process bus without LPIT. There are issues related to energy metering with LPIT. Benefits still harvested without LPIT are smaller cable trenches and small control building (less concrete). In addition, more data are available, and it can be easier to expand the substation.
- Remote access is important and must be realized for all IED's in the DS. This can limit the number of visits to the station and ease the investigation of faults etc. All components must have remote access option, both for the DSO and if desired access can also be granted to the vendors. If access is granted to vendors, all security related issues must be considered. There can also be some limitations in the equipment, for instance support for several network interfaces with their own settings for IP; subnet and default gateway. So, this point must be highly marked in the procurement specifications, not just an easy add-on late in the project.
- Optical current transformers must be specified with spare fibre for splicing. In one pilot the fibre broke in the OCT "Head." The OCT barely had enough fibre to do one splice. There are no valid reasons to not have an extra meter or two of fibre coiled up in the OCT. For initial trouble shooting the connection box for the OCT should be available from the ground with the busbar energized.

## 4.2 Engineering and design

The standard IEC 61850 defines engineering of a digital substation. It is a challenge that there is no standard architecture for DS and the architecture will also vary with criticality and size of substation.

Today substations are made with a bottom-up description, but it is challenging to update this with changes and upgrades. Helinks and similar tools have top-down approach that also provides good documentation and describe functions which can replace or be made in addition to circuit diagrams.

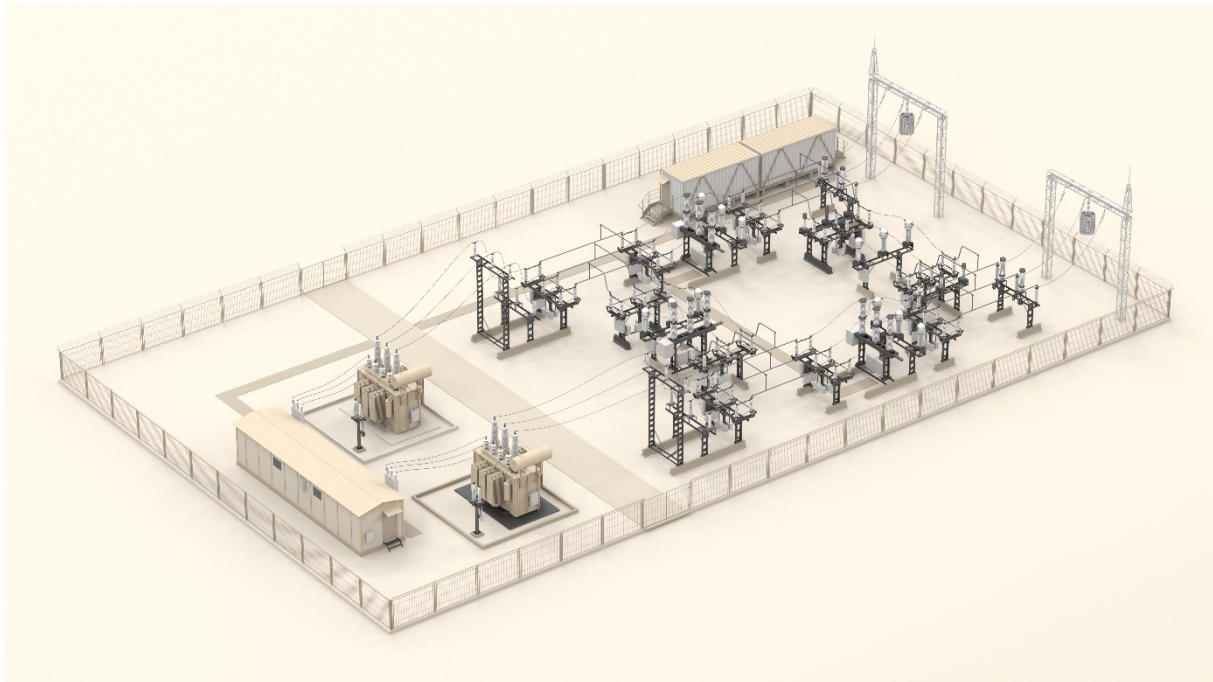

Source: Shutterstock

To do the IEC61850 engineering of the station in a top-down manner a specific tool/software must be used. This means that the substation system description (SSD) is engineered before IEDs are imported into the system. The SSD describes what “physical” components and IEDs are included, how they are integrated in the system, naming, LD, LN etc. It is a way for the user to describe in detail how a system should work and interact. This information can be extracted into (Substation Configuration Language) SCL files and imported into configuration tools for the control system. The details from the engineering tools can then be imported back into the model, and then you have a totally vendor independent model of the entire station. By a flexible export/import standardization in the 61850 platform, ideally several vendors can cooperate with delivery of different parts to the system.

The main goal for using tools like Helinks is to create a device independent, standardised, and formalised specification by using the IEC 61850 modelling concept. The system design performed by the system integrator must meet the specifications developed using third-party tool. The model developed by such kind of tools will always require some adaptation to different vendors data models, as there is a need to synchronise these models. It is possible to import CID-files (IED Capability Description) from relevant vendors to make “rules” for deviations based on their data model. This would result in IED-specific typicals as close as possible to the SSD. This would ensure a uniform implementation of a given IED in different projects independent of who is doing the engineering. Importing the final SCD file would highlight the deviations if any.

It is possible to describe all signals and signal attributes in terms of functional product naming to remain IED independent. Also, the information exchange of signal flow between functions including control and protection function should remain IED independent. It also makes it possible to have a single configuration file which is vendor independent and is easy to maintain, especially in terms of DSAS based on process bus. It also serves as a form of documentation. It is expected that third-party tools will make top-down engineering easier.

Templates for different bays in a substation, like line bay 420 kV, transformer bay 420/132 kV and so on can be made and shared. The SCD-file is an important part of the substation documentation. It should be ensured that all relevant information is available in the SCD file and only use static datasets. This combined with a good structure could result in a SCD that is more useable as documentation. The logical nodes from standard for troubleshooting like LSVS, LGOS, LTMS, CILO, etc. should be implemented. Vendor tools in one of the pilots were lacking support for importing SSDs and vendors had to manually generate each signal. This was very time consuming; this has improved in later generations of the software.

In one of the pilots, defining the IEC 61850 structure of the SCL file, connecting IEDs and other component including switches and clocks with correct substation, voltage level and the bay was the starting point for now. The naming conventions were also considered in this stage. The intention was to give our vendors a framework to do top-down engineering and to generate typical/ templates that will be used in future projects.

The experience of using the IEC 61850 based specification tool from Helinks for Protection, Automation and Control System have been good, it is a user friendly, vendor independent system that have been useful for the standardisation work. It is a valid concept. But still there is a long way to go and the tools are not mature enough for full specification work yet and the process itself is time consuming. The internal competence and available time to properly specify all signals was not available in the pilot projects. Such tools are promising and very relevant for engineering in digital substation, but it should also be investigated together with different vendors.

DSO/TSOs in Norway should build in house competence to develop the IEC 61850 engineering modelling cooperation with other DSO/TSOs in Europe. In the long-term perspective, the files generated from such IEC 61850 modelling tools will be a vital part of substation documentation.

#### **4.2.1 Protection**

In one pilot, upgrading of the protection went largely smoothly, but there was a need for testing after the upgrades. The extent of testing after upgrading has not yet been fully clarified and routines for testing after upgrading protection must be created. Lab set-ups to test upgrades before implementation on site is one option. There are different philosophies for patching of control systems, most only patch when they must (as little as possible). First-line expertise on this topic must be in-house. Risk assessment for patch jobs must be carried out. If necessary, patch requirements for different types of IT components should be differentiated. The vendors do not, in ECoDiS experience, always following up on upgrades to a desired degree.

Some issues due to the functionality/communication between new IED's on the market and parts of the network that are a bit older have been experienced. This was probably due to some changes in communication protocol or use of old versions of standards.



Source: Shutterstock

In the pilots we experienced that the process bus and MUs added complexity in the configuration and required more IEDs in the system. When this is included on top of a more conventional setup with one or more protection IEDs for each bay, the cost is much larger than a conventional system. When all measurements are available on the network, and most interactions with a substation protection and control system is through a remote connection virtualization of a bay should be sufficient. A centralized protection should limit the cost of hardware, installation, and space requirements. Making all measurements available in one IED could facilitate new protection functions or logics. Redundancy can be achieved with two devices.

The centralized protection used in one pilot can cover basic protection functions for about 15 bays. Two devices are installed in this pilot to cover all 22kV bays. Experiences are summarized below:

1. When connecting online the view is in theory similar to having a unit pr bay. It is fairly easy to navigate.
2. Supports simulation mode after an update before commissioning. This update was one of the issues that postponed the commissioning. Lacking support in other IEDs was solved by mapping simulated values only to the centralized protection. Another issue was different vendors responsible for setup.
3. Very compact 2x 19" 1U.

#### **4.2.2 Merging unit**

Redundant MU must be used where there is a need for redundant protection and in the case of shared ownership, and sharing of the MUs is undesired. The level of redundancy in digital

substations is being discussed and there is no best practice for this at the moment. Two MU for each LPIT is an absolute requirement for two-breaker and two protection-based system.

Physical replacement of a MU with a new pre-configured MU in one of the pilots was simple and went well, however, the experience in 5 years' time may differ. Moreover, the scope of the testing after replacing the MU is uncertain.

There are different requirements for sampling rates/security from the same MU for the use for voltage quality, metering, protection, and PQ. These requirements must be considered when specifying MUs. Moreover, the MU requirements can be different for different types of stations and must therefore be specified for each individual station. MUs must be able to take care of several functions, protection, control, and metering. The TSO prequalifies MU/SAMU in framework agreements, not per station.

### 4.3 Standardization

In relation to a conventional substation, DS causes the introduction of a lot of new technology. This affects both the devices included in DS and not least an extensive increase in the use of computer networks and communication protocols, which is important for different devices (IEDs) to communicate. The standardization will contribute to interoperability, which simply means that different devices can be linked together in computer networks and work together in a good way. The complexity of DS is large, and this also entails a need to use a lot of standards in the solution. The table below shows some of the standards included in DS.

*Table 1 Standards related to digital substation.*

Publisher	Name of standard/series	Description
IEEE	IEEE 802.3	A series of standards for wired Ethernet
IEEE	IEEE 802.1Q	Is the networking standard that supports virtual local area networking (VLANs) on an IEEE 802.3 Ethernet network.
IEEE	IEEE 1588	The PTP protocol is important for the transport of the correct time to various IEDs in the DS IEC/IEEE 61850-9-3 is a separate profile that is recommended for use in DS and is based on IEEE 1588
IETF	TCP/IP suite	The Internet Engineering Task Force is responsible for developing and maintaining standards (RFCs) for the TCP/IP suite
IEC	IEC 61850	Is the most important standard series for communication in DS. The series is large and comprehensive and covers several areas such as data modelling, data communication, configuration (SCL) and recommendations on the construction of data networks, etc.
IEC	IEC 61869	A series of standards covering the standardization of instrument transformers such as CT, VT and LPIT. Standards for SAMU and the digital interface at LPIT are also included
IEC	IEC 62271	High-voltage switchgear and control gear
IEC	IEC 60255	Measuring relays and protection equipment
IEC	IEC 62053	Standard series for electricity meters

As a spin-off of this project, NEK has developed the standard package NEK 860 Digital Station<sup>3</sup>. The package includes important standards in the IEC61850 and IEC61869 series as well as several standards for energy meters.

The vendors deliver some equipment that is designed according to old standards or that is not standardized well enough. This can also be a contributing factor to the vendors not carrying out type approval on their components. This is unfortunate for the grid companies, which lose functionality, interoperability and may risk replacing the equipment or renewing the DS before the expected life expectancy is achieved.

The use of standardized solutions is always important, but perhaps even more important when technology and solutions are immature and under development. Furthermore, standards will be important as the complexity of the station increases. IEC 61850 is also the standard that enables the realization of DS. There are many reasons why we should be very aware of the use of standards in the work with DS:

- The Norwegian authorities require that TSO/DSOs use standardized solutions.
- Strategic use of standards to strengthen buyer's market power.
- The grid companies have a strategic interest in DS being able to be purchased in modules, where standardization ensures functionality and interoperability.
- Enables the use of components from different vendors in the same station.
- Standards regulate how testing; type approval and certification should be done.
- The use of standards when specifying the DS will reduce the work of specifying requirements.
- Standards define terminology to ensure common and correct use of language.
- Use standards to increase competence.
- Participate in standardisation work to increase your own and your company's competence and influence development of standards.
- Know weaknesses/shortcomings in standards to know what you need to have own specifications on.
- Different vendors can have different interpretations of a standard. Many attributes are only optional. If a system is based on optional attributes in a standard, this could result in weaker interoperability or vendor lock in.

The IEC61850 Ed1 standard was released in 2003, Ed 2 in 2011 and Ed 2.1 in 2018. Not all vendors support the latest version 2.1, and some also support the guideline UCA 618509-2 LE (Light Edition) which is based on IEC61850 Ed 1. Due to different handling of information in some cases it can be difficult to mix variants of equipment that support different variations of the standard. This can have significant impact on the preferred solution and choice of components. In some cases, the equipment with the oldest standard supported sets the level for the standard the other parts in the same control network must be assigned to. So, when specifying the necessary level, set this as a requirement and clarify it with the vendors before purchase. From the purchaser's side, solid competence to understand the underlying problems is important to avoid these problems in the test and project phase. One potential benefit of DS is the mixing of product from different vendors, but this is not necessarily easy in practice and prerequisite good communication and agreements. The vendors have not coordinated which version of the standard they use. A Norwegian user group agreeing on which standards to use

---

<sup>3</sup> NEK 860 Digital substation - [link](#)

could help solve this problem. Support for PTP and possibilities of using flexible streams are the important updates from the earlier version (Light edition).

ECoDiS recommends using latest / newer versions of IEC 61850 series (ED 2.1)

Even if the backward/forward compatibility is handled in the standard, it is recommended to upgrade the clients to the latest version of a server instead of operating with different versions. Some information can be found here<sup>4</sup>.

IEDs like energy meters and tele protection units, which are normally separate deliveries should also support the same edition of the standard to make integration of these third party IEDs easier. These IEDs should also support the recommended redundancy protocols like PRP and HSR to avoid the use of additional IEDs like RedBoxes for supporting IEDs.

#### 4.4 Network

The network configuration is essential for correct functionality of the digital substation. When introducing digital substation concepts, the main challenge is to make the entire system reliable enough to fulfil the availability requirements of the system we have today. There are new IEDs available which are very reliability, but the new technologies offer an additional degree of freedom in the design of the whole digital substation system. However, IEC 61850 does not specify any kind of architecture nor demand for redundancy even in case of critical applications, this is left to the designer. It is necessary to pay close attention to the design in order to ensure high reliability.

With the process bus, new devices such as merging units (MU) for the optical sensors, as well interface units for conventional instrument transformers (SAMU), are needed. In addition, switchgear controllers for circuit breakers and disconnectors (“Breaker IEDs”) will be introduced. Those devices can be seen as conversion “endpoints” to and from the primary process to the secondary equipment. In a protection system, it is also essential to guarantee that a system fault is cleared within a strictly defined time period. To achieve and guarantee this operating time, the GOOSE packets for circuit breaker operation must be transmitted deterministically to the SCUs. It is important that the MU’s algorithm must match the algorithm in the relay. The manufacturer of the protective relay does not know the transient features of the MU and cannot guarantee its applicability. Therefore, a standardization of MU’s transient features is necessary.

---

<sup>4</sup> <https://www.pacw.org/versions-of-the-standard-what-you-need-to-know>

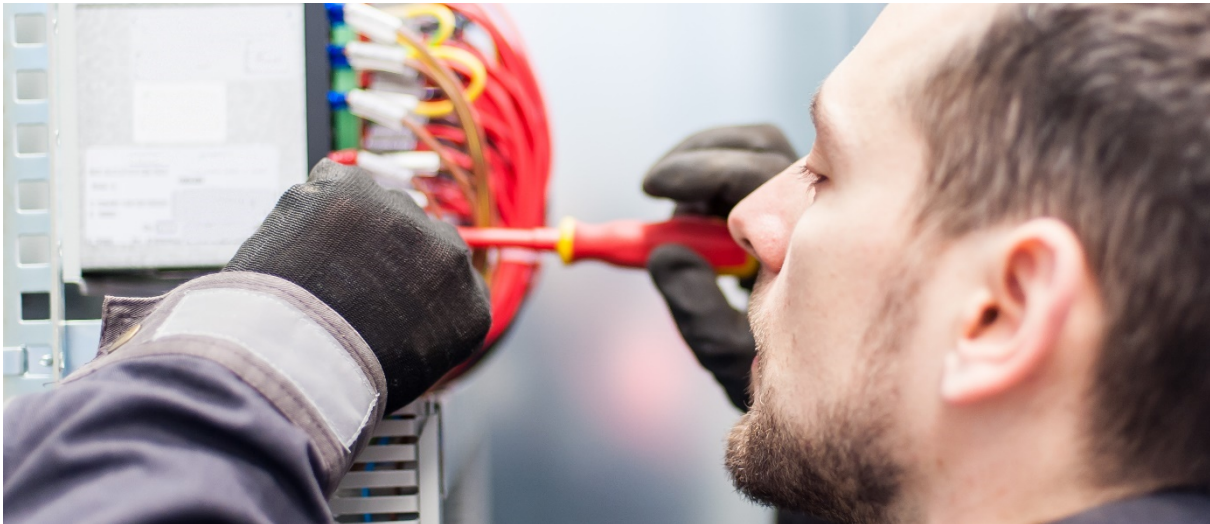

Source: Shutterstock

#### **4.4.1 Network design/ topology**

The process bus in digital substations introduces a new layer of complexity in the station network architecture. In a DS there are many “boxes” (from MUs to IEDs and switches) that are connected together, and which may all be points of failure.

The process bus network must have redundancy and be able to operate if a network component falls out. It is important that loss of redundancy is indicated to the operators. Redundancy can be achieved by using the Parallel Redundancy Protocol (PRP) or the High-availability Seamless Redundancy (HSR), see next subchapter.

There are many choices when it comes to architecture/topology, and it is not straightforward to make the right choice. It is important to have enough time to make a good topology in the design phase and consider the advantages and disadvantages of the choices made. Any unacceptable risks associated with the chosen topology must be handled. There are varying experiences with the different vendors on how they want to design the network and their competence on network design.

There are now up to five network ports on one protection unit and in the future, there will probably be more common logical or physical ports. This will require more “intelligence” in the switch to filter the traffic to facilitate routing of traffic between the sender and receiver. This means that the possible development will go in the direction of fewer boxes, fewer interfaces with mixed traffic of service, 61850-8-1 and 9-2, separated with VLAN and possible different IPs on same physical ports. Both operational (network load etc) and cyber security must be considered for this. In the future we expect even more centralization and virtualization of these components.

Metering adds one more layer of complexity with distribution of different measurements (SV) across the architecture. In the future, there will probably be different sampling rates for measurements used for metering and protection.

Connection of non-critical sensor data on the station bus is not acceptable for the operational control. This currently runs on its own network. This must be considered both due to security and capacity in the network.



The main discussion at the start of one of the pilot projects was how to establish a good network topology. All the network interfaces on the components, mix of 61850-8-1 (MMS/GOOSE) on station level and 9-2LE (SV+ GOOSE) on process bus to different receivers, handling of metering devices etc create challenges. Since the SV data streams generate a high network load it is necessary to segment the traffic. The backup protection and busbar protection for instance needs SV from all/several vendors so the switch must route the traffic to the correct receiver. It has been tested to solve this with MAC address filtering, but this was not possible when several receivers need the same GOOSE and SV's. Therefore, VLAN filtering was tried with success. With this method it is possible to filter and route the traffic such that the network is not overloaded, and functionality is maintained. Furthermore, there are several types of redundancy network protocols which must be taken into consideration when choosing the topology, see next subchapter. Some DSO/TSOs are also choosing the most cost-effective topology by combining station bus and process bus in one single physical network and having logical separation instead.



Source: Shutterstock

#### 4.4.2 Network Protocols

The Parallel Redundancy Protocol (PRP) and the High-availability Seamless Redundancy (HSR) protocol are defined in the IEC 62439-3 standard and are used to implement zero-loss redundancy on wired Ethernet. HSR nodes have two ports and act as a bridge, which allows arranging them into a ring or meshed structure without dedicated switches. This is in contrast to the companion standard PRP. Both solutions have pro and cons related to the number of switches necessary, risk and cost. At first view the HSR concepts seem to have advantages in costs for network components and infrastructure. No Ethernet switches are required, and cabling efforts can be optimized. But the cost advantage of HSR goes away as the size of the

network increases. Large networks require HSR rings tied together with RedBoxes or QuadBoxes. Also note that testing HSR networks may significantly increase operating expenses due to the need to re-cable the network during maintenance testing.

On a HSR ring only HSR ethernet frames are possible. However, as the HSR frames are not compatible with standard ethernet frames, HSR configurations are significantly different to standard ethernet topologies, and all devices on a HSR ring must provide HSR functionality.

The main challenge for digital substation concepts is to make the entire system reliable enough to fulfil the requirement on availability of the system that we have today. From this point of view, it is recommended to use the technology which is optimised for reliable and availability. PRP uses ethernet frames which are compatible with standard ethernet infrastructure. Therefore, the two networks are standard ethernet networks with standard ethernet switches. For each PRP network, any network topology can be used, any normal network concept applies, and any normal network tool is suitable. The switches simply need to support ethernet jumbo frames. As mentioned above, PRP definitely has some big advantages over HSR in terms of reliability aspects. Therefore, digital substations aiming for highest availability should be realised with process bus based on PRP network redundancy technology. The different vendors also have preferences and competence. The MU used in one pilot did not support any redundancy protocols, so a redundancy box (red box) had to be placed in between to add support for PRP. Table 2 summarises pro and cons of HSR and PTP.

Also note that Cisco seem to have some problems related to HSR, so PRP in that case is recommended.

*Table 2 Pro and cons of HSR and PRP.*

<b>HSR pro</b>	<b>HSR cons</b>	<b>PRP pro</b>	<b>PRP cons</b>
Less switches: two ports and act as a bridge, which allows arranging them into a ring or meshed structure without dedicated switches.	Higher cost: increase operating expenses due to the need to re-cable the network during maintenance testing.	Design is easy. Physically just one port in each direction towards the switch. Easy to design, operate and monitor.	Higher costs and complexity: More fibre and switches.
Cheaper due to less switches and fibre.	Limited capacity and unsuited for large substations due to traffic load.	For each PRP network, any network topology can be used, any normal network concept applies, and any normal network tool is suitable.	
Fewer components (switches) that can fail.	All devices on a HSR ring have to provide HSR functionality.	PRP uses ethernet frames which are compatible with standard ethernet infrastructure.	

PRP has been the preferred network protocol choice of most pilots in the ECoDiS-project. PRP is the recommended choice, although at the cost of more hardware.

#### **4.4.3 Other experiences and recommendations related to network**

- All IEDs in process bus must also be able to connect to a network that is designed for remote access, either through separate service port or via the station bus network. The use of remote access must be carefully considered due to security issues, especially remote access to external parties.
- Monitoring of the communication network port to all IEDs and time sources with SNMP/ or something similar is important. The function in the IEC 61850 in addition to SNMP and syslog should also be assessed.
- RBAC (role-based access control) - different roles are defined and tested, not all should be admin. This has been partially implemented at least in one pilot.
- When networks are loaded with multicast and broadcast type traffic, different IEDs will react in different ways. Some went into error mode at less noise than others. Tests of this were carried out on prototypes. It has not been tested on today's products. It is also discussed how relevant such tests are.
- Ethernet ports can generate noise in the event of a fault on the port. This was experienced on a station bus that consequently lost contact with the station. It has not been experienced on a process bus.

It is recommended to monitor abnormal conditions on networks to try to detect errors/problems, like a "health check" of the equipment.

- Check the capacity of component. Some components have a 100MB interface - filtering must be used in order not to get too much data load on the network. Such filtering is based on VLAN and must be used. 100MB is quickly overloaded, and VLAN filtering is used to separate the traffic.
- Difficult to set good security - leak of mac address - error in products (product error). Be observant and monitor as product errors will occur and the aim must be to detect them and prevent them from doing harm.
- Placing switches inside the control room will increase the level of physical safety, but then you end up in having lots of fibre cables between the control room and the primary equipment. Placing the network switch out in the field or in the GIS hall will give again the cost-effective design with less fibre cables but with disadvantage that the network components are placed in high-voltage areas of the substation.

Remember to also patch the switches within the DS. Crucial both for cyber security and functionality.

In ECoDiS, performance evaluation of Intelligent Electronic Devices (IED) under stressed conditions in the SmartGrid lab was performed. The performance was characterized as the time response in sending an output GOOSE message triggered by a received input GOOSE message or alternatively as the time response for the activation of a protection function. The stressed conditions were intended to represent a high level of computational demand in the device. This was achieved by loading the device with an increasing number of functions and subscriptions to

current and voltage sampled values. An experimental setup was developed to reproduce the conditions in a digital substation and to implement the method for characterizing the devices. The performance was assessed based on the Ping-Pong methodology and traffic packets of the experimental setup were processed with a customized analyser of GOOSE messages. This analyser captures the GOOSE messages of the devices under test and calculates the performance index [8].

#### 4.5 Time synchronization

A DS has higher requirements on precise timing compared to a conventional substation. The SV's must be correctly time tagged for use in busbar protection, cable differentials etc and the accuracy must be in the  $\mu\text{s}$  range. The lack of or fault in time synchronization can lead to trip of breakers or unintended blocking of functions.

There are different versions of PTP and for PTP V2 and later versions there are different profiles, so care must be taken when choosing equipment and agreeing on the methods to be used. IEC/IEEE 61850-9-3 Power utility profile based on IEEE 1588 contains the base profiles and is currently the most relevant standard.

In one pilot PTP transport from a central source to distributed protection units has been investigated. Prior to this, differential protection had its own GPS servers with antennas, or "black fibre cable" directly between protection units. However, it was problems with antennas and the electronics. The set-up with external antennas were also vulnerable in cases of external events. The DSO has concluded that the pilot functioned well for 4 route jumps, which is the number that has been realized so far. Consequently, it remains to be seen if it can handle more jumps. The number of error signals is reduced compared to the antenna solution. Since there are no antennas, maintenance work will be reduced. As of now, there is a need for servers, e.g. Meinberg, which translates PTP from tele- to power profile, but hopefully in the long run this can be realized in routers. The solution consists of a GPS server with an antenna in station 1. Station 1 has line differential protection against station 2 and station 3. In addition, there is line differential protection between station 2 and station 3. Station 3 is in a rock tunnel, which presents a challenge for the GPS antenna. PTP transport also solves this challenge. As part of the test, an extra "router" jump has been carried out in station 2 as an extra test, but this can be removed, see Figure 13.

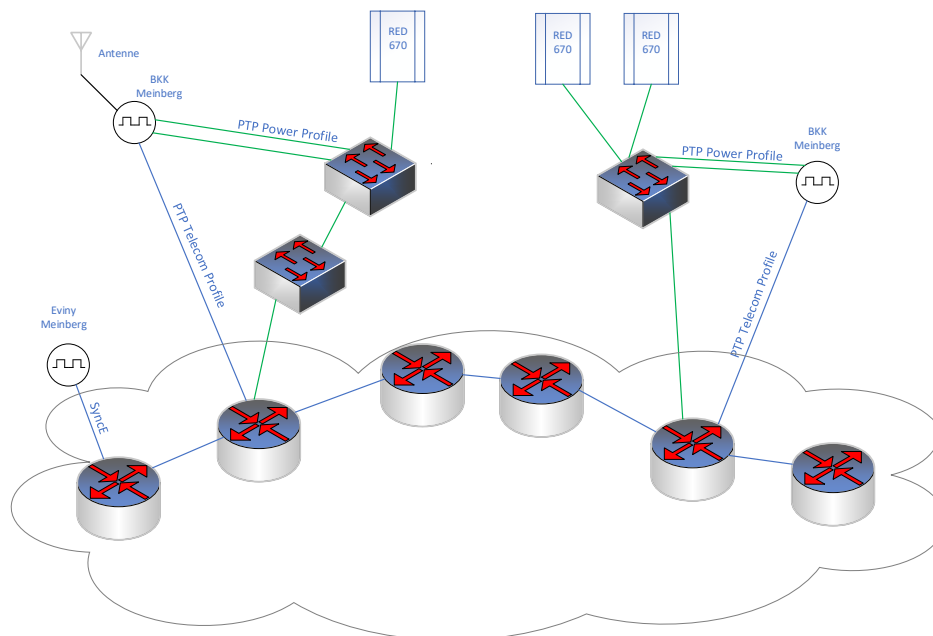

Figure 13 Time synchronization pilot of ECoDiS

The DSO has had some challenges with the use of GPS antennas/coax, and also the associated electronics and programming of this equipment. In one case, these challenges have led to an unwanted circuit breaker trip, probably because the GPS server distributed inaccurate time. It is important that the GPS server does not "sign up" before the time is correct. A solution without a global clock has now been chosen. Two IEDs in the station are used as clock sources for the process bus. The transparent clock is distributed to all IEDs using BMCA. There are no antennas for IEDs, but NTP is used for time indication. The DSO still operates a station with a global time source, due to the fact that this station also has line differential protection against nearby stations.

One experience from a pilot is loss of time source and the blocking of relay functions that subscribed to SV from the process bus. At the time there was no monitoring of internal fault. Now a bus bar protection is monitoring whether or not global sync is ok. The drawback of this solution is that there is no notification (alarm) if only one GPS fails, only if both GPS antennas are down. This system will function in island mode. It is quality bits in SV data streams that are monitored. One DSO has chosen to monitor all feeders (OR block) with time block in series. This is programmed into the bus bar protection, which has data streams from all feeders.

Monitor redundance of network and get notification to operation centre if protection is blocked.



Source: Shutterstock

One pilot was built based on IEEE1588 PTPv2 (2008) and power profile IEEE C37.238 (2017). All vendors relied on time sync (=global). One vendor additionally could rely on identical grandmaster ID in publisher and subscriber. During issues with time synchronization the vendor that could rely on both global sync and identical grandmaster ID typically experienced higher availability of synchronized measurements. The grandmaster clocks had an issue that if they lost and regained-GPS signal they would return to normal operation synchronised, but not reset the PTP-flag indicating “Time Traceable”. Due to this, IEDs that relied only on synchronization from a globally synced source would remain with local sync. IEDs that could rely on identical grand master only lost sync if the grand master experienced a drift in time before it regained GPS-signal. Restarting the switch corrected the Time traceable flag, but not the cause. An updated firmware was necessary to remove the issue. This issue was a persistent error that could be investigated based on live diagnostics and Wireshark recordings.

A few times every week the IEDs in one pilot experienced loss of sync for a brief period of time. It was observed that protection functions were occasionally blocked for a few seconds. Logs in the IEDs indicated loss of synchronization and subsequent blocking of protection functions. No issues were observed in grandmaster clocks or the network. Because the fault was spurious and of short duration, we supervised relevant sampled values and all PTP-traffic with a DANE0 400. It was set to trigger based on among other things “PTP sync error.” Two interesting issues were observed:

1. The DANE0 trigger levels are predefined. Even if the IEDs only reported issues a few times each week the Daneo triggered 50-100times each day. The trigger level is by default 500ns. 1000ns is OK for Sample values. It was found that 4 redboxes that also operated as a transparent clock was set to Two-step to be able to function as both transparent clock and to be synchronized as an ordinary clock. Other switches used one-

step. The vendors recommended that we use only one-step. After changing the settings to only one-step in Grandmaster and Transparent clock, the DANEO only observes a few incidents each week. The incidents correspond with IEDs reporting loss of sync.

2. Reviewing Pcap recordings indicate no apparent issue with the PTP signals. One manufacturer changes smpsync parameter in published sampled values from “global” to “none” for 10seconds. While the other vendor is not as frequently affected but we regularly experience loss of one second (4000 samples) inside the period the other vendor experience loss of sync. This issue is an ongoing case with our vendors.

In one pilot it has been experienced some short lack of valid time synchronization as well. However, the transformer IED's blocks the differential protection for a few milliseconds. The vendor and Meinberg had some dialogue regarding the problem, but it has been much better after some small changes in the system.

It has been beneficial to have the capability to trigger recordings of data streams based on events. 30s of a couple of SVs would be about 100Mb. To record continuously waiting for an incident or manually looking at diagnostic pages is not really an option if the system experiences fleeting errors.



Source: Shutterstock

PTP works very well most of the time, but troubleshooting can be difficult. Limited logging, or maybe the issues are not really in one device but more that it is a fairly new standard for substations. Different devices react different to the same event. Issues are only reported by the users, but the IEDs only indicate a general issue with time sync. Even relying on one vendor is not really enough to ensure identical behaviour. Switches used in a network should ideally be required to support identical settings and behaviours for PTP. One pilot had one vendor for switches but redboxes had some hardware limitations regarding what could be processed and still supplying one-step PTP.

For energy measurement, the correct clock/timing of SV in MU is critically important. Calculations show that the time deviation between sampling voltages and currents in separate MU should be less than 2  $\mu$ s.

DS must have a system for distribution and monitoring of local clock. The distribution between different IEDs can be 1pps or PTP according to IEC 61850-9-3

Time synchronization is a critical function in digital substation. It is recommended to have at least 2 or 3 reliable time sources in a station, and to distribute the time using Precision Time Protocol (PTP). Distributing PTP time between station networks is a good solution. For TSO level substations, global synchronization is recommended with a centralized atomic clock, in combination with 2 GPS clocks. Backup solutions is recommended, for example an IED or another local clock taking over as master clock. It is also recommended to specify how protection IEDs should behave during a loss of time synchronization or change of synchronization source.

Experience from ECoDiS suggests that TSO/DSOs should have ownership of networks and time synchronization. In order to have enough competence and experience, the same set-up should be used in as many substations as possible.

Emergency Preparedness Regulation § 7-14 on Special Requirements for Operational Control Class 2<sup>5</sup> includes a provision/requirement on secure time. This provision applies to local control in class 2 and 3 stations and will be applicable for digital stations. Operational control systems that depend on an exact time reference must have secure sources for time indication. The most important advice from the regulation<sup>6</sup> to the provision is that GPS receivers historically used in power supply may be insecure and inaccurate for complying with the requirement in an IEC 61850-based station.

Based on experience from different pilot and choice of time synchronisation it looks like global synchronisation could have some drawbacks with regards to process bus -based functioning. But again, it is challenging for the DSO/TSOs to maintain the different solution for implementing time synchronisation in different sub-station. The choice of implementation of time synchronisation should be standardised. The applications, need and future ambitions in a particular substation will impact the choice of solution either local sync or the global sync. Some DSO/TSOs prefer global time synchronisation over the local for process bus for the following reasons:

- Local time cannot be used for external synchronization, e.g. line differential protection
- During diagnosis, having two “time bases” add extra complexity
- Avoiding different time systems for different vendors
- Solution must be validated in lab before final specification

The need of synchronisation should be evaluated whether it is communication between substations, integrating data acquisition, PMU applications or process bus.

<sup>5</sup> <https://lovdata.no/forskrift/2012-12-07-1157/§7-14>

<sup>6</sup> [Kraftberedskapsforskriften: § 7.14 Særskilte krav til driftskontrollsystemer i klasse 2 \(nve.no\)](#)



## 4.6 Monitoring

Operation centre receives many new signals from the digital stations, and the number of signals is larger than from conventional stations. There is a need for interpretation of signals, for example which function is affected when the various error messages are received. One company has created a response matrix for the operation centre which include information on what they must do with different signals. There are more signals from the station than what goes to the operation centre, and these can have different recipients, see chapter on Service design.

In the long term, standardization work should be done on signals. There may be several messages about the same error from the digital station and therefore it is a need to specify, sort and prioritize messages and which messages should go to whom. Standardization work must be done, possibly creating lists with interpretations. Documentation in a DS is different than for a conventional substation, as IP addresses and function descriptions eventually may replace circuit diagrams. GOOSE matrix is an option telling which component sends a message to whom. Station scout can provide such matrixes. GOOSE monitoring is implemented in Sprecher IED in one pilot and sends an alarm when the expected GOOSE message is not received. Other digital aids should also be considered for monitoring purposes. Products are available in the market for better monitoring of data flow. Documentation of DS is challenging. Well-managed SCD files and digital tools such as station scout or OpenSCD are perhaps best, but more functional /text/figure descriptions are also needed at a higher level. One company has good experience with dynamic interlocking matrix on local HMI and they plan to mirror this to SCADA.

Different vendors are developing the tools to the monitoring of both sample values and GOOSE in the substation. Utilities should try to use them and establish the standard for supervising these types of signals.

## 4.7 Physical design



Source: Shutterstock

The same regulations apply to components both on the outside and inside of a building.

EMP (electromagnetic pulse) protection can be ensured in different ways:

- In one pilot, the part of the bay cabinet containing IEDs was EMP protected was used to reduce the cost of the cabinet in an AIS substation. But it is evaluated that the design for AIS system bay cabinet could be a kiosk containing all equipment. This will not only ensure EMP protection but also a solid protection against the weather.
- To get good EMP protection according to requirements, the type of door, door lock, gasket and duplicated cabinet wall must be sufficient.

Field cabinets in general:

- The temperature in the field cabinet should be kept within the recommended temperature range of the equipment and 10 degrees above the ambient temperature could be a rule of thumb. However, the summer temperature can be high, so be aware of the max/min temperatures of the equipment. Cooling might also be necessary. Cooling fans in the cabinet introduce mechanical components that require maintenance/failure, and something that should be considered. A heating element is included today for both low temperature and avoiding high humidity. Monitoring of field cabinet temperatures should be performed, with alarms for high/low temperatures to the operation centre
- DS field cabinets might require more keys (as the cabinets must be lockable) and must be kept track of who is using them and where they are located. The balance between inaccessible for unauthorized persons and accessibility for employees (This can become problematic in case of errors) should be evaluated.

- Today, the design of the cabinet has not considered the need for maintenance by personnel. For example, during winter opening the doors will cool down the equipment, consequently the electronics must be protected. One company has installed a roof that can fold out when the door is opened due to temperature, rain, snow etc. A kiosk will also solve this problem.

So far, standard fibre seems to be good enough for DS and no need for fibre with a higher mechanical quality. Some DS have offshore specified fibres. However, standard fibre is easier to replace and so far, seems to be good enough for DS. No deterioration of condition has been detected on standard fibre so far.

Some of the aspects of field cabinet design to take in consideration are:

- Climate. Temperature and humidity.
- Installation work and procedures (lifting, civil works)
- Work environment and accessibility for maintenance.
- EMP and EMC if they are the specific regulatory requirements
- Access and security

#### 4.8 LPIT

The market for LPIT in GIS seems more mature than for AIS and there are fewer vendors of LPIT for AIS, at the moment. A vendor survey was carried out by Statnett to clarify the status of the development of LPIT. Some vendors have stopped development of stand-alone AIS - LPIT because of the limited market and the focus is LPIT for GIS installations for voltages from 145 to 550kV. Generally, vendors are putting considerable resources into the further development of both LPIT and MU. The conclusion of the vendor survey was that there are sufficient vendors who can largely fulfil our needs for LPIT (except settlement and accreditation), especially for Rogowski-based GIS LPIT. On the other hand, CIGRE has made a survey saying more about optical current transformers implementation than Rogowski coils have been installed worldwide. There are benefits using LPIT in AIS (see Chapter 2), so the situation might change in the years to come. If Norwegian TSO/DSOs, ask for LPIT for AIS this will help create a market for such components. The energy metering issues, see chapter 4.11, slows down the use of LPIT, hence it is important to solve these issues.

In one pilot of ECoDiS both 22kV and 132kV GIS breakers were equipped with Low Power Instrument transformers. The advantage of LPIT is that it results in less cabling through station indoor/outdoor, eliminate high short circuit effects, saturation, and less space (due to compact design) compared to conventional instrument transformers.

Generally, the nominal performance of LPIT is beyond the measuring accuracy of the MU. There is hence no need to replace the LPIT when changes are implemented in a substation, the same sensor can be used everywhere in all stations, which makes it easier to manage spare parts.

The signal from the primary converter to the merging unit is most often a propriety signal which in turn requires a vendor specific MU (merging unit), which in turn results that different vendors must cooperate within the project for integration of these components.

It is very important that already in the contract phase this responsibility and necessity for cooperation between different vendors is clearly defined and associated. As merging unit will be the part of the complete protection, control, and metering chains.

During commissioning of transformer bays, one DSO experienced that the inrush current measured by the optical current transformers caused tripping of the differential protection, see Figure 14. When the circuit breaker was closing during energization of the transformer it superimposed a high frequency current on top of a typical energization current. This appears to be due to vibration spreading in the foundation of the breaker and the instrument transformer. To solve this, the LPIT's was mounted on separate stands. Conditions were improved but the issue was still present. In the end the issue was solved by adjusting a logic in the differential protection to only rely on 2<sup>nd</sup> harmonics for inrush blocking of the differential protection. The superimposed high frequency current is observed when no current is flowing prior to closing of the circuit breaker. It is not isolated to transformer bays, but only transformer differential protection seems to be affected in a significant way.

Temperature sensors are necessary for LPITs to achieve a measurement class of 0.2S for metering. Most protection functions do not require the LPIT to achieve a measurement class. It has been observed that issues with the temperature sensor and the measurement correction it is used for can influence measurements for protection functions. Measurements for protection should be independent of any additional measures to improve the quality of other measurements. In our experience vendors use quality attributes limited to valid and invalid for sampled values. Maybe it could be beneficial to use a greater range of quality attributes such as questionable – inaccurate.

One optical current transformer lost measurements in one phase after less than one year in operation. Initial testing of the fibre indicated that the failure was in the head of the OCT. The fibre was successfully spliced on-site in late autumn. Troubleshooting required support from a fibre optics specialist, and this could impact time to repair. During troubleshooting one path was found to have much larger dampening than the other healthy path. It was found that the fibre was contaminated in the connection point leading to high dampening of the signal. Such faults can be difficult to detect, and lead to unstable measurements. It is important to always wash or rinse fibre connectors and contacts after disconnection before reconnecting. After splicing it was commented that the available spare fibre reserved for splicing was very short. It is important to ensure that manufacturers leave sufficient spare fibre to enable on-site repairability during the OCTs expected lifetime.

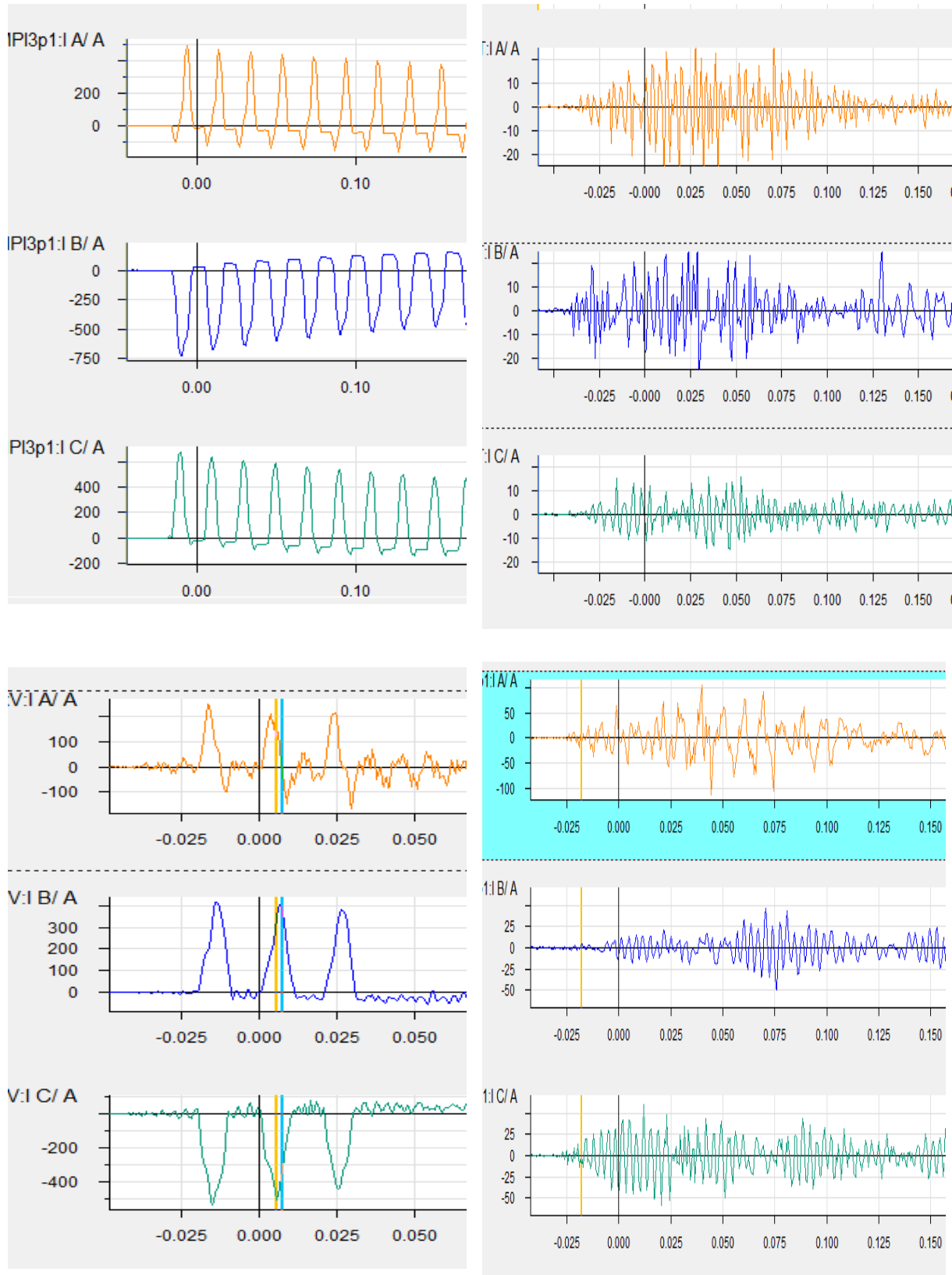

Figure 14 Inrush current measured by the optical current transformers caused tripping of the differential protection.

Important elements in a LPIT specification:

- Sensor duplication - should there be different sensors (duplication) for protection and measurement?
- Standards - the entire IEC 61869 series and IEC 61850?
- How sensitive are the measurement results to vibration, temperature, and humidity?
- EMP requirements - AIS/GIS - single component or system requirements?
- Accuracy class measurement and protection
- Sampling frequency protection, measurement, and voltage quality?
- Turnover- primary turnover, up to 1% measurement accuracy class 2s
- Interoperability - prequalification MU with protection and rest of the control system
- Cooperation with protection vendors, if not the same.
- Redundancy
- Requirements for replacement, change and upgrade
- Requirements for spare parts?
- Fiber connection, splicing, length
- Verification of complete protection chain.
- Remote access MU and SNMP
- Short circuit value for protection core
- Documentation and testing
- Requirement for cyber security and patching
- Accredited calibration according to ISO/IEC 17025

Other things:

- There is a need for equipment for testing and calibration for LPIT in the operational phase
- If there is shared ownership of digital substations the interface and data exchange must be discussed and agreed

Example of shared ownership between TSO and DSO:

- Owner A: Owner of the busbar and the entire substation, except for e.g. transformer bay/bays
- Owner B: Owner of transformer bay (s) - both high voltage and low voltage and the transformer itself

Signals to be exchanged:

- Switch positions for interlocking
- Current measurements from the bay for busbar protection
- Voltage measurement from busbar for synchronisation check

## 4.9 Energy metering

At the beginning of the ECoDiS project, we started with good knowledge of conventional substations and conventional energy metering in MV and HV installations. The knowledge of DS and energy metering in DS based on LPIT and process bus started at a very basic level. Throughout the project, we have gained some insight into the topic, but still have more questions than good answers on how to achieve good quality energy metering in DS. The transition from conventional energy metering to LPIT/process bus-based energy metering is a major shift and is not an evolution. This will lead to large changes in competence requirements, replacement of both technology and components in the metering chain, and extensive use of

data networks and communication protocols. Furthermore, there are shortcomings in methods for verification of the metering chain and an absence of best practice in the field. Time is working for the technology, but it will most likely take some years to establish enough knowledge, methods, technical solutions, and good metrology in the field.

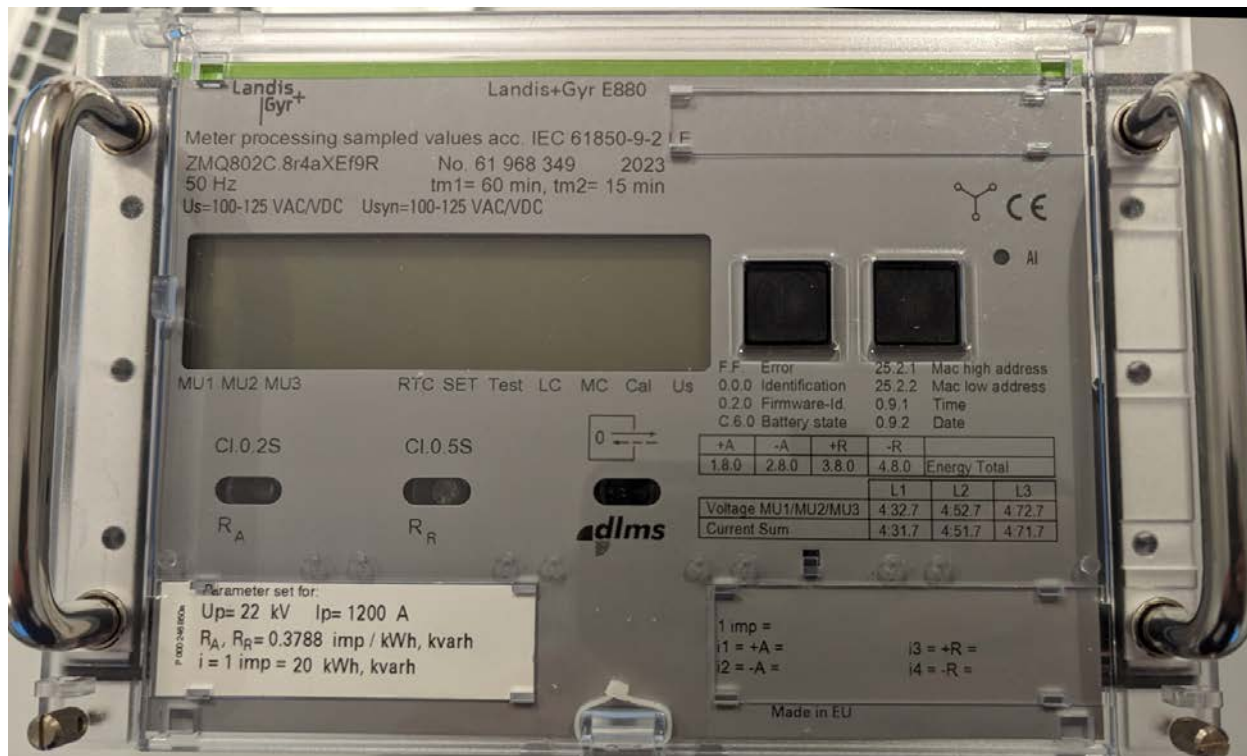

Figure 15 Energy meter from Landis+Gyr.

One of the most important learning points in the work with energy metering is that the subject area seems to be quite immature with regards to implementation of digital substation with process bus. This means that development in energy metering is behind the development of other disciplines at DS.

PACs (Protection, Automations Control system) is a term that is often used in connection with DS and the use of IEC61850. For those of working with energy metering, there should be a M for “metering” included in the term, a proposal for new terminology might be PMACS.

If one searches for information regarding energy metering in DS, one will find 100 research article or other literature on the topic of protection for each result on the topic of metering. This suggests that energy metering has not been a prominent topic in relation to DS. In conversations with the vendors, we also get the impression that the energy metering function in DS has not led to establish metering as a separate defined discipline with associated experts. We often get help from experts in protection, process bus, LPIT, merging units (MU), and meters. These are skilled experts in their field but lack some understanding of energy metering and metrology. Some of the DS design choices made also show that the same solution is used for protection and metering, and it appears that the solution is more optimized for protection than metering. When using conventional CT, the same core will never be used for metering and protection. In DS you will find such design used, and it might not be a good solution.

When buying and selling any commodity, it is important that the buyer, seller, and authorities can trust that the quality of the "weight" is good enough. In some cases, this is regulated by law as consumer legislation, examples of this in Norway are shop scales, petrol pumps and electricity meters for use in the low-voltage network. This is called legal metrology. In the MV and HV grid, there are laws such as the Energy Act, the settlement regulations and regulations from the Norwegian Metrology Service that provide legal requirements for the facility owner who is responsible for establishing energy metering and is responsible for ensuring that the quality is satisfactory. The legislation rarely sets specific requirements, often requiring quality assurance, internal control, and systems to safeguard quality. The TSO (Statnett) requires its customers to use metering in accordance with Requirements for Metering (KTM), this document sets requirements for conventional metering in the transmission grid. Here there is a requirement for a total maximum measurement error of 0.5% at nominal load. The metering chain must be calibrated by an accredited calibration laboratory. Furthermore, the DSO owned company REN has published guidelines for conventional metering in MV and HV network.

Norway, together with other Nordic countries, has a common Nordic electricity market that needs good metering data to function well. This applies to both the quality of the measured quantities and the availability of the measured values. In Norway, there is also a lot of settlement of electrical energy between many players who are connected to MV and HV networks. The power market is constantly evolving, and this place increasing demands on the performance of energy metering in the distribution and transmission grid.

Two workshops were arranged in ECoDiS with energy metering as the main topic. In one of these workshops, the vendors of DS were invited and prior to the workshop, a draft of requirements for energy metering in DS was prepared. The requirements and questions related to these were sent to the vendors in advance. ECoDiS received many useful answers, but there are still unanswered questions that need more work and research. ECoDiS desires that the vendors increasingly understand that energy metering is an important part of the delivery of a DS.

Requirements and calibration routines for energy metering in digital substations must be developed. It is considered an advantage if these are prepared jointly with other countries and made applicable to several countries or regions.

For a large share of substations built in Norway, there will be a need for energy metering for billing purposes. Here, a lack of documented quality /opportunities to verify the metering chain on site will be a **showstopper** for the introduction of DS as a preferred solution for substations, until there is a solution for metering that the parties can have confidence in. The vendors who deliver DS should therefore have strong incentives to develop good solutions for energy metering in DS.

On the other hand, there are already ongoing some R&D initiatives to make metering application virtual. It is expected that the high-quality data from digital substation in the future will eliminate the need for physical control of the measurements. The alternative methods will be developed, and they will ensure that the quality of the measurement used for billing purpose fulfil all the requirements. The utilities are also looking for parallel installation of both conventional and low power instrument transformers and not the least energy meters to get confidence and trust in technology.



### 4.9.1 Energy metering in pilots

One pilot substation was originally planned to be a conventional substation where it was possible, in the tender, to offer a DS as an option. The DSO had not used a detailed specification of requirements for DS. This meant that the vendor's own design choices were mostly used. The decision to have a pilot related to energy metering was also made after an agreement had been established for the construction of the DS. It was originally planned that a total of three digital meters would be established in the substation. For various reasons, it was decided to only install one digital meter. This was placed on the 22 kV side of transformer T1 (132/22 kV, 40 MVA). Here it was not possible to obtain LPIT with sufficient accuracy class, so conventional CT/VT was used. In Norway, there is a need for internal settlement on feed-in to the 22 kV MV distribution grid. For the settlement, L+G E850 conventional meters are used. To realize digital measurement, the same CT/VT that is connected to a conventional meter is also used for SAMU. As a digital meter, L+G E880 has been utilized. It remains to establish a digital meter on incoming lines of 132 kV and 66 kV in the substation. Here, a LPIT has been used, which is mounted on the GIS. The LPIT is combined with LPCT and LPVT in the same unit. The LPCT uses Rogowski coil, but the LPVT uses capacitive voltage divider as sensor.

One of the tasks planned in the pilot was to review the solution the vendor has used in the station. The vendors were therefore asked to send technical documentation on LPIT, MU and documentation on network nodes used in the process bus as well as circuit diagrams and device lists at the station. We received circuit diagrams for the data network in the station and some early-stage circuit diagrams. We did not get documentation on LPIT and MU. There was also a desire for a technical review of the facility together with an expert from the vendor, but we were not able to carry this out either. It is perceived as very unfortunate that the vendor has not provided the required documentation. The DSO needs this information to operate the substation and to meet legal requirements. The activity of describing the vendor's solution for energy metering was therefore not finalised. The digital meter E880 first came into operation in May 2024. Therefore, it has not yet been possible to compare measurement data from conventional and digital meters.

L+G E880 is a meter type that will be taken out of production in 2024. L+G will soon be able to deliver a new meter type E860. It can also be mentioned that there is little availability of other types of digital meters in the market. Upon delivery of the E880, it was discovered that the meter had been delivered with RJ45 Ethernet input for SV even though fibre connections had been ordered. Regarding the meter itself, one can see some weaknesses that will probably be improved on the new meter version:

- The meter is not built according to any standard as there is no existing standard.
- The meter does not support connecting multiple networks and PRP/HSR redundant protocols are not supported. A solution to this is to use a RedBox.
- The meter's display does not show the vectors of currents and voltages. Special test equipment needs to be connected to the process bus to check that the meter is correctly connected.
- On the E880 there is only one input for auxiliary power. This reduces reliability compared to conventional meters that can also get auxiliary power from measuring voltage.
- The E880 has limited ability to monitor and monitor SV quality and packet loss.
- E880 has limited ICT security.

- E880 cannot be read by L+G AIM HES which is the most widespread HES used for L+G meters in Norway.

The traditional metering verification at the point of measuring is no longer possible in a digital substation. Standards and routines for testing and metering quality assurance must be updated. Vendors of energy meters must also be challenged to provide separate components/data streams for protection and metering. The energy sector needs to discuss the advantages and disadvantages of separation of metering and protection and most importantly where the point of separation should be. Digitalization of substation includes a rethinking of routines and requirements. In some areas, traditional routines and requirements are not relevant anymore, new ideas and alternatives must be made to meet the aim (which is unchanged): correct energy metering for all consumers connected to the power grid. Energy metering does not necessarily have to follow the old practice, however, it is crucial to verify the accuracy of the chosen method.

Vendors of GIS LPIT should work towards standardising the output from the sensors so that it can communicate with any third-party MU and give the possibility for more interoperable system integration. DSO/TSOs across the countries should work together to establish the common requirement for LPITs and the requirement for metering. There are no requirements for energy metering using LPIT in Norway now. Such requirement should be in place prior to using digital energy metering for settlement.

Challenges regarding PQ nodes and metering have so far not been resolved and may therefore result in a traditional solution with CT and VT in combination with LPIT. If separate measurement chains become relevant, duplication of Low Power Instrument Transformers must be considered.

#### **4.9.2 Components in the metering chain**

Here is a brief description of components and other important factors that affect or may affect the quality of the energy metering. Some of the points that emerge may be weakly justified and are included to point out the possible problem and possible solutions to the problem.

Figure 16 shows which components are included in a digital metering chain. As one wants to build substations with different technologies such as GIS or AIS and many different configurations of voltage levels, design of switchgear layouts and layouts for stations and networks, we will get many variations on the design of the metering chain. The figure also shows how a digital measurement chain can be established.

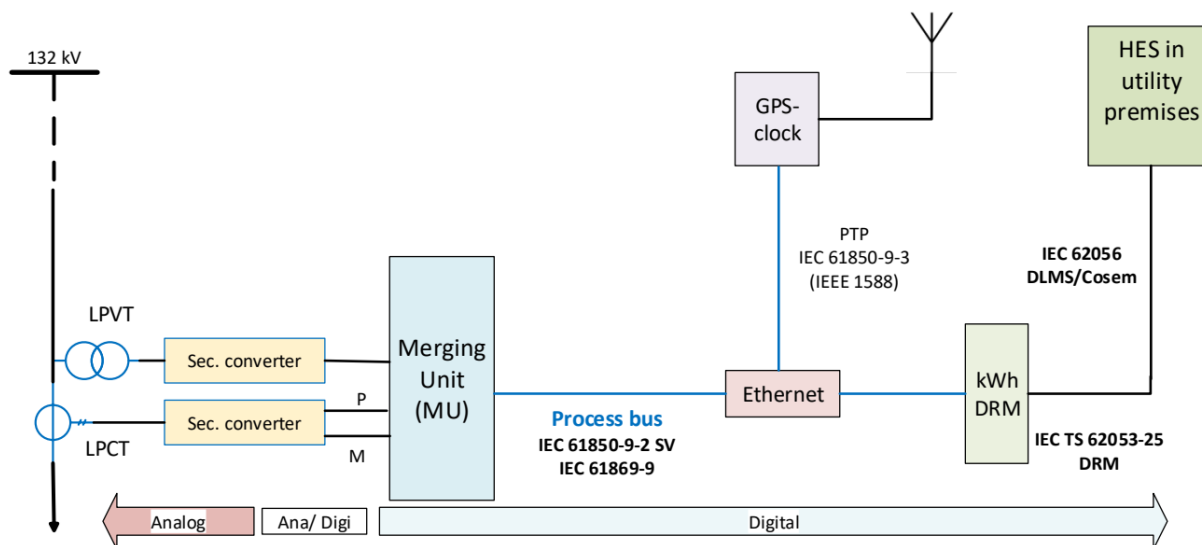

Figure 16 Digital metering chain.

## LPIT

On GIS systems, the most common configuration is to deliver combined units where LPCT and LPVT are mounted in the same housing. The widespread measurement principle for LPCT appears to be the Rogowski coil. For LPVT, the most widespread measurement principle is capacitive voltage divider. Based on the design of LPIT, cable length and time delay in sampling and processing in MU, it will be possible to get time delays between primary current and voltages and time indication on SV based on MU. It is recommended to make assessments of this and especially whether there may be different delays on conversion U and I. Such errors could contribute to significant errors in the energy metering.

### Recommendations LPIT:

- It must be considered to use different sensors for protection and metering on LPCT.
- Both line bay and transformer bays with metering should be equipped with LPCT and LPVT.
- LPVT and LPCT at the same bay/ metering point shall be connected to the same MU. This is to reduce the risk of poor time-sync between two different MUs.
- The LPIT must be designed according to the latest versions of the IEC 61869 series
- The vendor must submit certificate of type approval of the LPIT
- LPCT and LPVT must be supplied with a calibration certificate in accordance with ISO/IEC 17025.

## SAMU/MU

SAMU/MU will be a central part of the instrumentation for energy metering in DS. Important tasks such as digitization in ADC, timestamping of the sampled values and interfaces with the process bus will take place in MU.

### Recommendations MU:

- MU must be built according to the latest versions standards of IEC 61869 and IEC 61850 series.

- MU shall be able to deliver dedicated SV data stream / process bus for energy metering.
- The SV for current measurement used for metering should be scaled for metering (not for protection)
- MU shall support redundant protocols such as PRP/HSR.
- MU shall support 1PPS and IEC/IEEE 61850-9-3 for time synchronization.
- The preferred sampling rate for energy metering is 14400 Hz. 4000 Hz sampling rate should also be supported. (cf. IEC/61869-9 Clause 6.903.3)
- The vendor must submit certificate of type approval of MU.
- MU must be supplied with calibration certificate in accordance with ISO/IEC 17025

### **Process bus (PB)**

The process bus will be critically important for correct energy metering. It is assumed that the process bus must be dimensioned and set up correctly for the energy metering to function satisfactorily under all operating conditions.

#### Recommendations PB:

- It is recommended that the minimum speed of the process bus is 1 Gigabit (For example 100BASE-FX)
- The maximum load (duty cycle) on the process bus must be kept significantly lower than the rated bandwidth on the PB.
- Process bus for metering should most likely be separated in own VLAN or physical LAN.
- The process bus should be equipped with a monitoring / watchdog that can monitor traffic volume, packet loss, faulty clocks, and fault conditions in the network.

### **Energy meter**

TC 13 WG 11 is in the process of preparing IEC TS 62053-25 ED1 Electricity digital revenue metering.

#### Recommendations energy meter:

- Meters must be in accordance with IEC TS 62053-25
- Meters for settlement purposes must have three measurement elements.
- Meter should support sampling rate 4000 and 14400 Hz for 50 Hz systems.
- Meters must support redundant networks (HSR/PRP)
- Meters should meet the requirements of IEDs according to IEC 61850.
- Meters must be able to be supplied with reinforced or redundant PSU.
- Meter must monitor and register deviations in communication on the process bus and the quality of SV. Packet loss, errors on quality bits on SV must be logged and create an alarm in the event of exceedances of configurable limit values.
- Meters must have a security separator/firewall between the process bus (IEC 61850) and the meter/meter communication (IEC 62056)
- The meter's display must show measurement quantities per phase and total for U, I, P, Q, angle between U and I, power factor and energy registers A+, A-, R+, R- as well as clock, date, and frequency.
- Vector images must be able to be displayed on a display or otherwise handheld device with a simple data connection to the meter.

- The vendor must submit documentation of type approval of MU
- Meters must be supplied with a calibration certificate in accordance with ISO/IEC 17025

#### **4.9.3 Other metering recommendations in DS**

The solutions for metering offered in today's market cannot be recommended for use for settlement. This is mostly since the solution has no documented measurement capability and cannot be verified on site.

- The metering chain shall be designed and maintained so that the actors in the electricity market can have confidence that the settlement will be correct.
- The measuring chain shall have a total maximum measurement error for active energy of 0.4% at nominal load.
- The manufacturer of LPIT should establish a program for monitoring drift (Metrology drift) on each type of LPIT. The method must be recognized, and all measurements must be carried out by an accredited calibration lab in accordance with ISO/IEC 17025. The results of monitoring drift must be openly available to the parties. This applies to a selection of different types of LPIT, and testing can take place both in a lab environment or outside at selected facilities.
- All metering in MV and HW network should be carried out as 3-system measurement, i.e. performed with 3 LPCT, 3 LPVT and electricity meter with 3 measurement elements.
- Metering chains must be documented by the vendor. This applies to all components included in the metering chain, interfaces, connection points, cabling, circuit diagram, use of standards and configuration of IEDs. All components must be clearly labelled according to a standardized reference system.
- To monitor energy data from electricity meters, station balances and line balances must be established automatically. Moreover, deviations should be reported. This can be done in the central systems at the DSO/TSO premises.
- When new measuring technology is implemented, greater accuracy requirements should be striven for. This requirement must not be set so low that it results in a significantly higher cost or that the requirement becomes difficult to maintain during the lifetime of the measuring chain due to drift and measurement uncertainty during field calibration.
- More research should be done on how energy metering is affected by errors in the transmission of SV and other incidents in the process bus. Proposals for recommendations for best practice should also be prepared.
- More research should be done on how to ensure the correct clock on IEDs and how errors in time synchronization in MU and other IEDs affect the quality of the energy metering. Proposals for recommendations for best practice should also be prepared here.

#### **4.9.4 Metering chain verification**

A prerequisite for being able to use metering based on LPIT / PB for settlement purpose is that the metering chain can be verified. Verification here means an on-site accredited calibration of the metering chain according to ISO/IEC 17025. It is considered a great advantage if regional

and international cooperation can be established to ensure good metrology in energy metering in DS.

Recommendations metering chain verification:

- NMIs must ensure traceability and calibration of instruments in the metering chain at the national level. Examples of instruments included are LPIT, MU and meter.
- NMIs must assist with the development of methods for verification of the metering chain in calibration lab and on site.
- Requirement documents for energy metering in DS must be developed at the national level. In Norway, this could be Statnett requirements for metering. It would be advantageous if the requirements were harmonised across national borders.
- A method should be developed for calculating total accuracy in the metering chain and a method for calculating total measurement uncertainty.
- It should be considered whether primary injection on LPIT can be used for calibration of LPIT and MU on site. It should be considered whether to use a full-scale or small-signal primary injection for verification of the measurement chain (system test) on site.
- A method must be developed for accredited calibration of the metering chain on site.
- A method must be developed for calibration of instruments used in metering chain and the whole metering chain on site. The calibration laboratory must be accredited according to ISO/IEC 17025 to carry out a field calibration.

#### 4.10 Condition monitoring of primary components

The advantage with condition monitoring of primary substation equipment such as transformers and switchgear are that we can get:

- **Improved asset management:** condition-based maintenance and early warning of developing faults in primary components
- **Improved grid utilization:** more dynamic loading of the components (for example, safely overloading power transformers for short periods of time)

The main challenge for condition monitoring is to plan and construct the necessary infrastructure to collect, distribute and interpret the sensor data. This has been a clear experience from all ECoDiS pilots that include systems for condition monitoring. Another challenge is that the sensor instrumentation may fail, or give false alarms, which leads to costly troubleshooting, confusion, or unnecessary precautions.

It is recommended to carefully plan the infrastructure for collecting, distributing and using condition monitoring data in the organization at an early stage of a digital substation project. Data streams/networks for asset management should be completely separated from the PACS networks. Data processing on-site (edge computing) should be utilized to reduce the amount of data to be transported. It is also recommended to develop better techniques for utilizing and acting upon the condition monitoring data.

A hypothesis in the ECoDiS project was that the digital substation infrastructure could speed up the integration of condition monitoring systems, for example using digital twins and AI. In the ECoDiS project, two machine learning techniques for monitoring were developed at SINTEF. One was a technique for predicting transformer hot spot temperature in power transformers

based on internal temperature sensor data. The potential benefits of having multiple hotspot sensors inside the power transformers were also investigated [9]. The second machine learning technique tested was an anomaly detection algorithm for switchgear vibrations during closing and opening of a switch. Using accelerometers inside the operating mechanism of AIS switchgears in the laboratory and in one of the pilot stations, vibrations were logged during closing and opening of the breaker. However, the machine learning models were not developed to a sufficiently high TRL (Technology Readiness Level), partly due to a lack of field data. In general, the experience is that the AI/digital twin technology for condition monitoring is at a low TRL. However, it is wise to invest efforts into such systems, as their potential for improving asset management and grid utilization is high.

The IEC 61850 protocol, for example station bus with MMS communication, is often suitable for condition monitoring in digital substations. However, depending on the monitoring application and the network architecture, other protocols may be better. For example, separate monitoring networks, or communication via cellular (4G or 5G). There are also several dedicated IoT protocols that may be considered for some types of sensors. See example network infrastructure concept in Figure 17. When planning to implement condition monitoring of primary equipment, it is important to first plan and build the necessary infrastructure to distribute and use the data. Data processing on-site (edge computing) is useful to curtail the data transport and could be considered for some purposes. Thereafter the following should be considered:

- Is there competence, infrastructure, and resources in the organization to operate and maintain the monitoring system?
- Is it clarified how the organization will collect, handle, interpret and use the monitoring data?
- Does the monitoring system have negative effects such as introducing cyber-security vulnerabilities?
- What is the criticality of the primary component and outage costs?
- What is the probability of component failure?
- What is the probability of detecting errors before failure with the condition monitoring equipment? Are the capabilities and limitations of the monitoring equipment well understood?
- Can the monitoring system be useful for other purposes? Examples: competence development or data collection for AI applications.

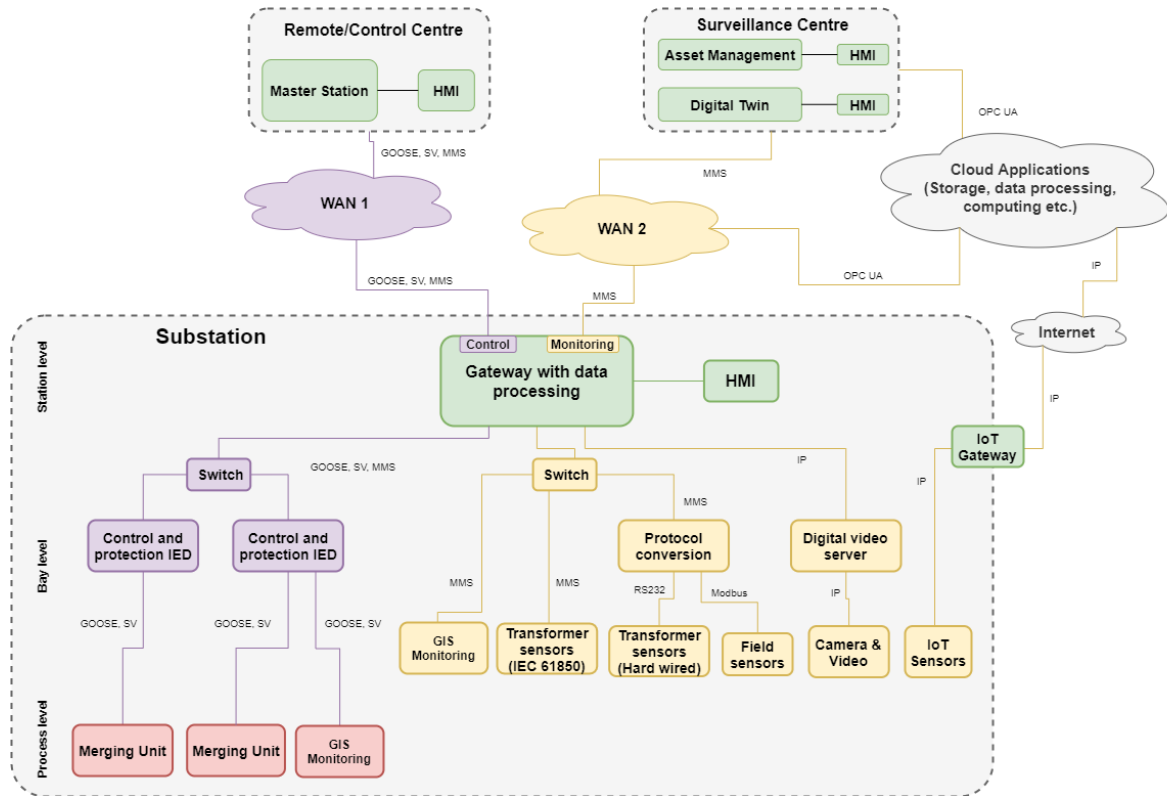

Figure 17 Concept sketch for collecting and communicating various condition monitoring data from digital substations, using different protocols and separated networks.



Source: Shutterstock



A system for detection of PD (Partial Discharge) and noise sensors which detects UHF (ultra-high frequency) was installed on the GIS [2] of a pilot. This system can be used to monitor early fault detection and asset health. The PD panel controller was then connected to the IEC61850-8-1 station bus and the signals were readable from the station RTU and health data could then be sent to the central SCADA system. Unfortunately, there was not time to gain a lot of experience with this system.



Source: Shutterstock

#### 4.11 Service design

To target the benefits of digital substation a service design process was used. Digital substations require new competence and introduces new types of problems in all parts of the organization. It is therefore wise to map out the different roles. To do this, different personas<sup>7</sup> were identified. For example, the dispatch centre engineer and line worker both work with the digital substation, but have different information needs and face different types of problems with the technology in the day-to-day work. With “service design” for a digital substation we mean the mapping of user needs and expectations to the digital substation within the organization, separated on the different roles. A good service design is very helpful for implementing digital substations.

For the service design approach applied in one pilot, four different personas were used: Operator, Maintenance planner, station worker and protection expert. Several people inside the

---

<sup>7</sup>Personas are fictional characters, which you create based upon your research to represent the different user types that might use your service, product, site, or brand in a similar way. Creating personas helps the designer to understand users' needs, experiences, behaviours and goal

organization were interviewed to map a typical persona with details like age, education, seniority in the company and motivation, to more specific questions about the digital substation such as today's tasks related to a substation, what is working, what is challenging and what would you like to change. Even very specific questions such as what problems you think can be solved by obtaining real-time information directly from the station and what information do you require.

The main takeaways from these interviews where:

- The possibility of detecting minor faults faster, and not depending on on-site inspections.
- Reduce time-consuming operations such as traveling to the station several times to solve the same problem.
- Intuitive description of signals
- Need for more specific training for new systems.
- Easily accessible trend graphs for selected signals
- Automatic generation of alarms and tasks
- Logical filtering of alarms

The work resulted in a user journey description as shown in Figure 18 below where each operation with corresponding personas were mapped together with the data need and description of the user interface required.

This was later used to design a prototype for dashboards specific for each user. In Figure 19 an example of a dashboard is shown. This was later engineered in a functional first version. The experience with using these dashboards has been very limited due to challenges in APIs and data exchange from the on-site services required.

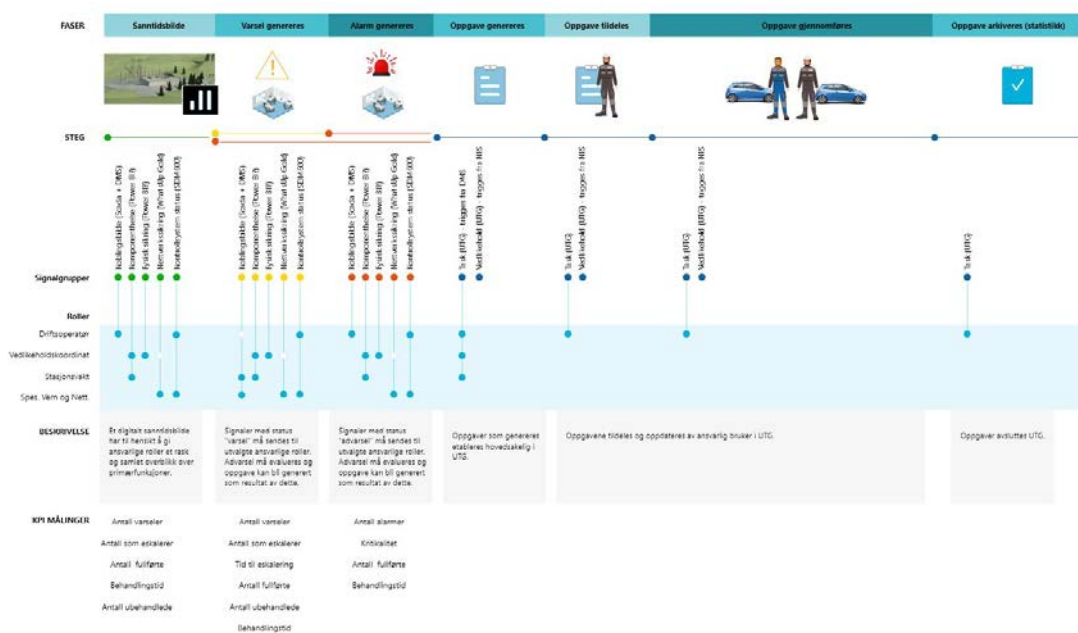

Figure 18 User journey from service design.

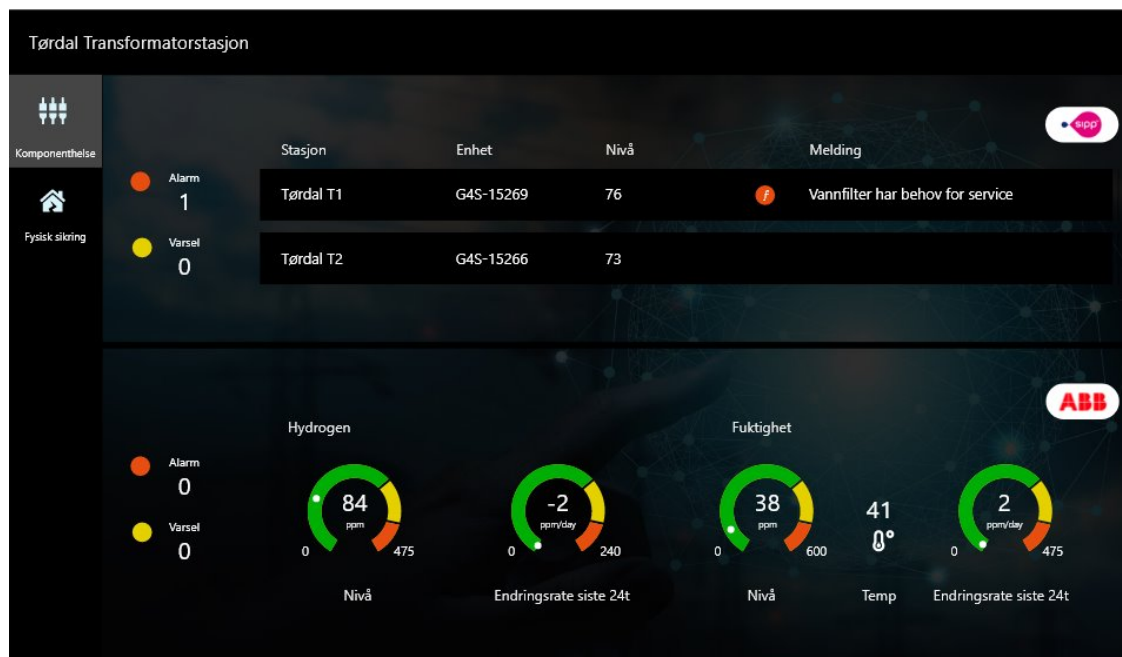

Figure 19 Example of dashboard based on service design.

## 4.12 Operation and troubleshooting

### 4.12.1 Testing and troubleshooting

When designing the substation and process bus, it must be planned for the connection of local test equipment. In addition, remote access must be arranged for all devices, as far as possible. Procedures for testing protection functions and logging onto networks must be made, but also training for personnel must be conducted. One DSO has bought test equipment for testing and carried out some tests, but on this topic additional efforts are needed.

There are different topologies in different stations, for example the use of HSR or PRP, and which signals are available in the different networks. Facility-specific documentation should therefore be created, so that it is possible to test and troubleshoot. It is important to understand the networks, to avoid incorrect connection with the unintentional trip of circuit breakers as a consequence. The need for competence in ICT/networks is increasing, and training is important, both theoretical and practical. The need for spare parts for use in lab testing activity is relevant, but the DSO has so far not implemented this.

For a new substation, much of the testing is done in factory (FAT), and some at site (SAT). However, the DSO/TSOs must ensure that it is possible to do complete testing of all substation components also after the commissioning, as updates or changes to the substation will be implemented throughout the station lifetime. This should be communicated clearly during procurement. All IEDs should have capabilities for testing and simulation and should have pre-defined testing functions and the possibility to de-activate logical nodes for testing purposes.

To avoid leaving IEDs unintentionally in test mode, it is recommended that the IEDs give some kind of warning signal if they are left in test mode. Test ports on the network switches for reading traffic or injecting SVs is useful, but it must be possible to deactivate these ports for security reasons.

It is recommended to define a testing procedure/protocol before beginning tests, especially if the tests go beyond the specified functionality. The testing and simulation functionality must also be defined in the main SCD file. A good testing order is: i) network, cyber-security, and time synchronization, ii) station control functions, iii) SV and GOOSE setup iv) each bay and v) the complete system. When test protocols are developed by the vendors be aware of the purpose of the test. Is the aim to test what is probably working or to stress test the system? Testing is important and the extent of testing necessary must be identified.

A multi meter is a key tool for troubleshooting in conventional substations, but it is not suitable for troubleshooting a digital substation. For digital substations, investments are required in testing equipment and software such as Omicron CMC and Station Scout, and the competence to use these. Commitments for troubleshooting personnel and resources from the OEM are also necessary.

There are components which are part of the protection chain which may not, normally, have a testing function. For example, some MUs have an amplifier unit. Failure modes for these components, and appropriate testing and/or redundancy schemes should be clarified.

#### **4.12.2 Patching / upgrading**

The various software and firmware components in a digital substation can require patching, and hardware such as network switches or IEDs will need replacement during the station lifetime. It is recommended that the DSO/TSO has a clear patching philosophy, differentiated on the type of component/software. The DSO/TSOs must have the sufficient competence to perform the patching work and to do basic troubleshooting or have committed support from the OEM. It is recommended to have a digital twin or an inhouse laboratory platform where the effect of upgrades and patches can be tested before implementation. It is highly recommended to perform risk assessments before a patching job and avoid all unnecessary patching and upgrades. Redundancy of network either by PRP or HSR is highly recommended considering aspects of patching and upgrades in the operational phase.

#### **4.12.3 System tools**

It is recommended to get familiar with system tools for IEC 61850 substations. Although it requires a good deal of competence to use these tools properly, they can be useful in the tender phase and for documentation of the digital substation architecture. In addition to the vendor specific tools, there are other alternatives such as Omicron Station Scout, Helinks, or OpenSCD. For documentation with system tools, it is recommended to keep version-controlled SCD files describing the substation topology.

Acquire your own testing equipment and get familiar with the test equipment in cooperation with the vendor. It is important to be able to perform tests and therefore essential to build internal competence.

### 4.13 Local and remote control

Different control locations:

- Remote
  - From control centre
- Local
  - Local HMI
  - Control panel on cabinet (via display and buttons on IED, and push button)
- Close proximity/emergency
  - Control without interlocking

Local control can be solved by having a local/remote switch either in the IED or as a separate switch. When set to local, buttons in the cabinet or at the IED front can be used (defined as local control).



Source: Shutterstock

It is necessary to have a setup in the substation control room for emergency disconnection of circuit breakers in the station in case of fault in the control system (Scada/HMI, Network, RTU etc.). One way to solve this is a time limited interlock override via a button on the IED. There

are also other solutions. Emergency control for circuit breakers (button on breaker or from control room) as a last resort.

Emergency control via station LAN has been tested at the TSO only for circuit breakers. But if both station and process buses are down, such emergency control will not work. Further on, there can be mechanical emergency operation on medium voltage switchgear and hard-wired trip circuit/out command for emergency operation of the (high voltage) 132 kV switch which provides extra security (this requires specific training of personnel).

See also chapter on regulatory requirements.

#### 4.14 Competence

As digital substation is a paradigm shift for the energy sector having employees with the right competence in the DSO/TSO and at the vendors is of great importance. Equally important is the competence of those newly qualified entering the energy sector and the competence within the universities and research institutions. The EcoDiS-project has had two workshops to identify competence needs and necessary actions to fill the competence need. We observed changes between the two workshops in May 2022 and October 2023: more companies had gained experience with DS and felt a more urgent need for new competence; hence all the companies had made or was in the process of making strategies for competence development. In addition, there was a clear need for more lab tests related to DS. There is a need to test more features of DS both before installation and during operation. Some lab activities can be done at each company or vendor, but some of the testing can be done in the SmartGrid laboratory<sup>8</sup>.



Source: Shutterstock

<sup>8</sup> <https://www.sintef.no/en/latest-news/2023/testing-out-a-digital-substation/>

Recommendations concerning competence:

- Create a Norwegian user group for DS for exchange of experiences, standardisation purposes and realising the necessary actions related to competence
- Continue to contribute and share knowledge through dissemination in general and more specifically in international fora's like CIGRE and standardization organisations, both national and international, like NEK and IEC
- Make a company strategy for DS competence: who, how, when. Competence can be both in-house and externally. For external competence it is important to be realistic related to response time. For in-house competence, the necessary time must be available as building competence in addition to a full-time job is challenging
  - First response to events in DS must be in-house, while other competence is strategic choices
  - In-house competence require training at a regular basis and such training must be organised
- Make a company strategy for lab testing of DS: both prior to installation and during operation there is a need for testing, and this can be done in-house, in cooperation with vendor and/or in external labs like SmartGridlab
- Contribute to education by being guest lecturer and suggesting and supervising bachelor/master thesis
- Evaluate if you have the right organisational structure or cooperation initiatives/culture to support DS, as DS needs closer cooperation between what is now different departments/groups in a typical DSO/TSO

One DSO experienced that personnel became uncertain of what to do during incidents and has therefore carried out training. However, there is a need to repeat such training on incidents, in addition to getting used to daily operation of a digital substation. Digital stations have less traditional bypass in the control system, and this must be considered in planning and training.

#### 4.15 Retrofit of existing stations

Many older transformer stations, especially in urban areas, have indoor air insulated busbars (45-72kV) where the mechanical, thermal and electrical data of the busbar is unknown or incomplete. The arc calculation will in many of these cases show that you will be way over the acceptable arc energy regarding personal and operational safety.

To resolve this, you can change the properties of the primary components or reduce the time before a fault in the high-voltage busbar is cleared. The expected lifetime of the high voltage equipment like busbar, breakers, etc, is 2-3 times as high as the expected lifetime of a protection relay. So, to resolve the issues mentioned above in some older transformer station we chose to install new protection relays compatible with IEC61850-9-2 flexible streams for current measures, see Figure 20. In such a concept the IED is working as a protection relay and sometime also as a standalone merging unit (SAMU). A new centralized busbar protection IED that subscribed to the current streams in the network was installed. For tripping all the feeders, the trip command is distributed through GOOSE (LGOS) using the same network. Some of the CT may be changed due to higher requirements for other protection functions such as distance protection, but for the busbar protection it was only needed to change the protection relay.

## Busbar protection using 61850-9-2

The principle for measuring current and voltage for the busbar protection with conventional CT & VT

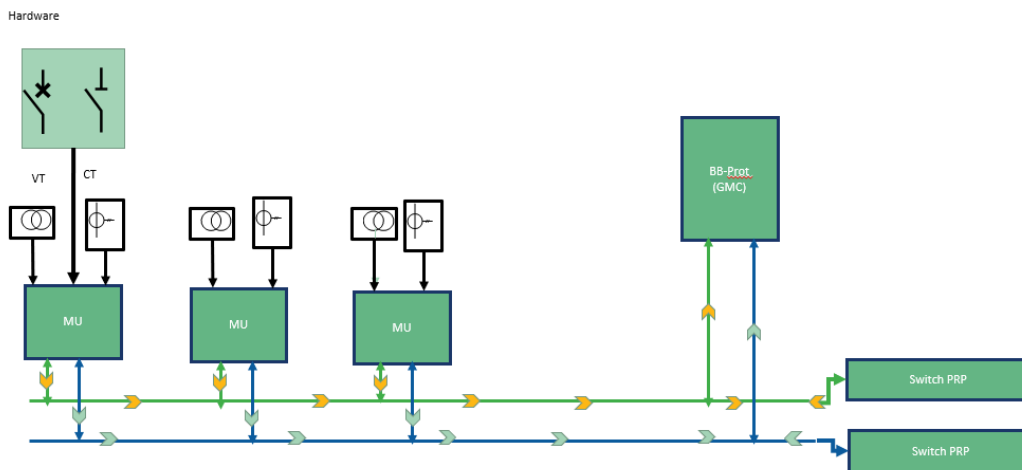

Figure 20 Principle scheme for busbar protection with IEC61850-9-2 and conventional CT/VT.

In this concept, the centralized IED for busbar protection is also working as a local Grand Master Clock (GMC) and provides time for the local network for busbar protection. In an early stage of the concept development, a GPS antenna was connected to both switches, including a link between the switches. During the testing of this concept, problems with the GPS signal quality (placement of antenna etc) and also with the SW logic that should choose the clock with the best quality (2 clocks in the same subnet) were experienced. The problems with SW logic caused an alternating clock source and overflowed the system with error messages. In contrast, a dedicated GMC clock source ensures that the busbar protection will work independently, regardless of any external errors such as a GPS downtime, fibre breakage (global time) etc. The busbar protection IED will also need the status of switches in all connected feeders, thereby all information needed to realize breaker failures is provided. However, there are some design weaknesses with this concept, such as lack of redundancy with only one IED used as MU and the centralized IED for busbar protection / breaker failure. This concept using a network with 1 IED/MU system working together with 2 redundant PRP switches is shown in Figure 21. If there is only one IED/MU per feeder the system will be blocked in case one unit is out of service. For example, if a test handle is used during relay testing, the sample values with current measurements on the process network (red and green lines in Figure 21), will be marked with a test bit (test flag). The centralized busbar protection will then automatically go into block-mode.



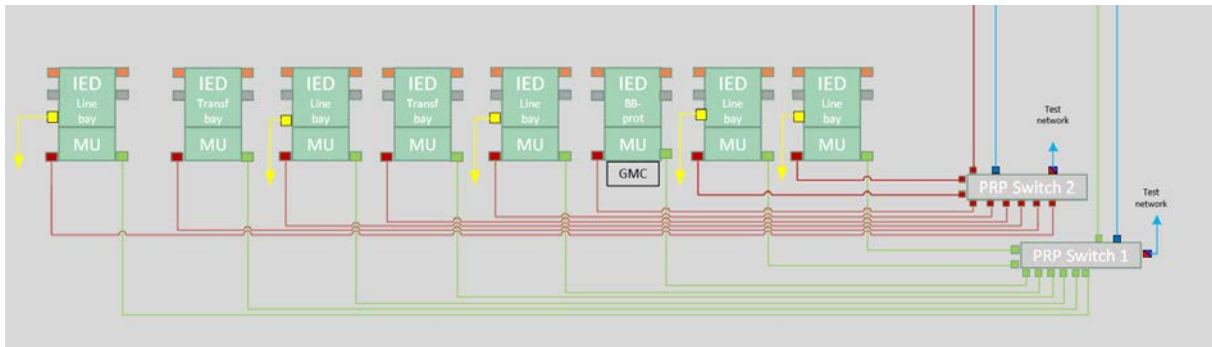

Figure 21 No redundant protection system for busbar.

A network with 2 IED/MU system working together with 2 redundant PRP switches is shown in Figure 22. The busbar protection is completely redundant in this concept.

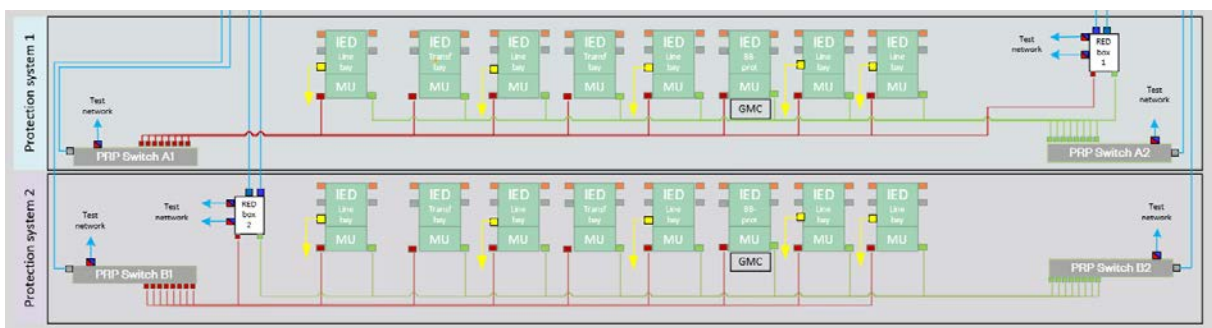

Figure 22 Redundant protection system for busbar.

#### 4.16 Cyber security

OT (operational technology) environments such as digital substations are as vulnerable to cyber-attacks as other IT environments. As such the same cyber security measures needs to be put in place to reduce the risk of faults or disruption caused by cyber-attacks.

Digital substations should be designed with the use of both the IEC 62443-series and the IEC 62531-series.

The IEC 62443 series is a set of international standards for cybersecurity in industrial automation and control systems (IACS). It addresses security for all IACS lifecycle stages, focusing on risk assessment, secure system design, implementation, operation, and maintenance. The standards define roles and responsibilities for asset owners, service providers, and product suppliers, ensuring a comprehensive approach to cybersecurity. Key components include requirements for security policies, procedures, technical controls, and continuous monitoring. IEC 62443 aims to enhance the security and resilience of critical infrastructures against cyber threats.

Security levels (SL) in IEC 62443 define the degree of protection against cybersecurity threats in industrial automation systems. Ranging from SL 1 (basic protection) to SL 4 (advanced protection), they guide the implementation of security measures based on risk assessment,

ensuring appropriate defences against increasing threat levels and attack sophistication. We recommend using SL 3 or SL 4 for digital substations.

IEC 62531<sup>9</sup> series of standards include cyber security technologies for some communication protocols used in digital stations. The IEC 62351 series also defines the cyber security requirements for implementing security technologies in the operational environment, including objects for network and system management (e.g. with SNMP), role-based access control (RBAC), cryptographic key management, and security event logging.

The dependency on time for DS functions can be an attack point for i.e. foreign states. ECoDiS has not any experience on this, but it is worthwhile to discuss with the vendor and have back-up time solutions. External connection to the process bus should be avoided. Dedicated PCs where DSO/TSO have full control should be used for Omicron equipment (omicon CMC 356 (or 430) Omicron station scout) etc. to troubleshoot, so that the vendor's PC is not connected to the process bus.

Patching of process bus-switches is important for cyber security, but in one pilot, which had internally delivered switches, this has not been successfully executed yet. KRAFTCERT alerts on switches from vendors are difficult for DSO/TSO to follow up as it can be work intensive for DSOs/TSO to upgrade according to recommendations from KRAFTCERT, when the firmware is old.

NTNU Gjøvik and SINTEF Energy Research have performed research related to cybersecurity. The papers are in these references [10], [11], [12], [13] and [14]. Relevant references from the CybWin-project<sup>10</sup> can be found here<sup>11</sup>.

## 4.17 Regulatory requirements

### *Contingency of supply and emergency preparedness*

The regulation on security and emergency preparedness in the power supply system, §7-8 *Contingency Due to Failure in the Operation Control System* it says that: *Companies shall establish contingency plans and have remedial action plans to secure uninterrupted operation in the event of failure in the operation control system.* This is also valid for DS and companies need to update routines and plans for this and also perform exercises to test if they are compliant<sup>12</sup>.

---

<sup>9</sup> [IEC 62351 - Cyber Security Series for the Smart Grid - SyC Smart Energy](#)

<sup>10</sup> CybWin: <https://prosjektbanken.forskningsradet.no/project/FORISS/287808>

<sup>11</sup> Cyber security: <https://app.cristin.no/results/show.jsf?id=2231967> and

<https://app.cristin.no/results/show.jsf?id=2273408>. Test lab:

<https://www.rpsonline.com.sg/proceedings/esrel2022/html/S23-03-411.xml>. Vulnerabilities in time synchronization: <https://app.cristin.no/results/show.jsf?id=2153403>

<sup>12</sup> Regulation on security and emergency preparedness in the power supply system:

<https://webfileservice.nve.no/API/PublishedFiles/Download/5690526d-60af-4cd5-b7fc-51c87cb66f48/202119965/3425769>



Source: Shutterstock

To be compliant the correct equipment, competence, and time to conduct tests need to be available. Advanced test equipment needs to be available, and companies must rethink their spare part strategy. New types of spare parts may be required for digital substations. The topology (placing of equipment) is also important for security reasons. Smart topology can ensure that equipment is not destroyed during failure and that bypass/interlocking functionality is easily available. It is important to think through what to do if equipment stop working. Local control buttons must also be considered, as it provides an additional manner to control the station. Four levels of control are recommended: operation centre, HMI, IEDs and buttons directly on components, see also chapter 4.13 Local and remote control. The use of digital substations makes it necessary to think through all failure scenarios and make sure that the preparedness is on a correct level.

### **Cybersecurity measures**

The Norwegian Regulation on security and emergency preparedness in the power supply system <sup>13</sup> includes the direct cyber security requirements for digital substations in Norway.

To be able to be complying multiple cybersecurity standards are relevant. For digital substations both the IEC 62443-series and the IEC 62531-series should be used to translate the Norwegian requirements to international standards. A basis for mapping between

---

<sup>13</sup> [Forskrift om sikkerhet og beredskap i kraftforsyningen \(kraftberedskapsforskriften\) - Lovdata](#), English translation: [Kraftberedskapsforskriften: Regulation on security and emergency preparedness in the power supply system \(nve.no\)](#)

requirements and standards can be found in the guidance<sup>14</sup> for the regulation. This mapping is not designed specifically for digital substations and needs to be expanded.

## Safety

In digital substations in Norway, we must closely adhere to the Regulations on Electrical Supply Installations (FEF), established by the Directorate for Civil Protection and Emergency Planning (DSB). Effective since January 1, 2006, the regulations impose strict requirements for the safety, design, execution, operation, and maintenance of electrical installations. With digital transformations, it is crucial to reassess compliance with these regulations, considering the impact of technological changes. This involves conducting risk assessments, applying relevant international standards, and adjusting internal procedures to ensure new digital systems do not compromise safety, health, or material assets.

An example of the specifics for digital substations, non-interlocked control from a safe location is crucial for Health, Safety, and Environment (HSE) compliance. This ensures operational safety and mitigates risks. For example, using Intelligent Electronic Devices (IEDs) for remote monitoring and control requires implementing the level closest to non-interlocked control to maintain secure and reliable system management.

Control of circuit breakers and other switches without interlocking from a safe location, like a control room, must be in place. It is suggested that the level closest to non-interlocked is considered for use, e.g. IED. But personal safety should be considered, especially when the IEDs are placed close to the high voltage switchgear. Some pilots also evaluated to have hardwired out command for circuit breakers from the control room as an emergency control in case if there is failure of the entire network (process bus and station bus).

### 4.18 Future challenges

Development related to the process bus happens fast and the pace of change is high. It is likely that the digital substation technology will evolve in the direction of further virtualization of protection and control functions. Meaning that IED functions will be implemented on a server, which is located at the substation or, in some cases, elsewhere. IT competence (in combination with OT competence) will likely be even more important for future substations. This will mean that the physical size of the control rooms can be significantly reduced. Furthermore, the control facilities will to a greater extent be able to be operated and managed as mission-critical ICT systems, with opportunities to automate testing. This could contribute to higher digital security, but also a simpler and much more efficient regime for upgrading. Getting full confidence and control of the process bus is a necessary intermediate step towards the future control systems and not the least integration of LPIT and primary high voltage component with digital interface. Centralized protection system must support 1 Gbit/s

---

<sup>14</sup> [Kraftberedskapsforskriften \(nve.no\)](#) (Norwegian)

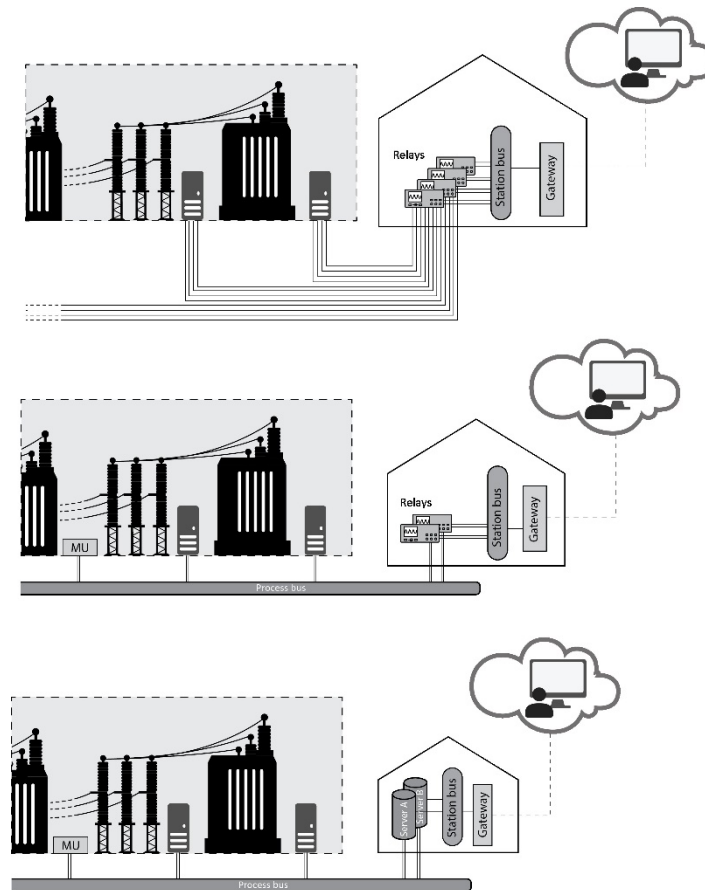

Figure 23 Future development of DS.

Tools to monitor the 61850-station bus with a particular focus on digital measurements are under development. The purpose is to notify of deviations as early as possible to avoid unwanted incidents, based on data collection from protection units and the use of machine learning (artificial intelligence).

Some unresolved issues have been identified in the ECoDiS-project. These need to be addressed before full rollout of process bus as a new standard solution:

- How to get added benefits out of process bus data and what kind of infrastructure is needed both locally at the substation and remote.
- LPIT and issues with calibration and accreditation of sample values so that LPIT is accepted for metering application.
- More high voltage equipment that directly has the process bus interface so that there are fewer boxes out in the field.
- Optimal solution for time synchronisation depending upon need of the user.
- Operation and maintenance strategies.
- Testing and patching strategies.
- New competence.

## 5 Bibliography

- [1] K. Pollestad, C. Gebs, Judendorfer and Thomas, “LPIT operational experiences and challenges in a Norwegian digital substation,” in *CIGRE ID10969*, 2024.
- [2] K. Pollestad, J.-L. Rayon, C. Gebs, H. K. Meyer, A. Mjelve, A. Luciol and A. Sarr, “Experience with commissioning of a 132 kV SF6-free digital substation,” in *CIGRE ID10960*, 2024.
- [3] R. S. Loken and e. al, “Experience with process bus in Statnett R&D project Digital substation,” in *CIGRE Session B5-203*, 2018.
- [4] N. Hurzuk, R. Loken, O. Tungland, L. Stensrud, B. Ohrn, H. Hauglin and T. Dunker, “Implementation of time synchronization in the Statnett R&D project - Digital substation,” in *CIGRE SC B5 Colloquium*, Tromsø, 2019.
- [5] S. Sanchez-Acevedo, S. D’Arco, N. Hurzuk and R. Løken, “Performance Evaluation of Intelligent Electronic Devices under Stressed Conditions,” in *IEEE Madrid PowerTech, Madrid, Spain, 2021*, pp. 1-6, doi: 10.1109/PowerTech46648.2021.9495081., 2021.
- [6] S. Sanchez-Acevedo and S. D’Arco, “Towards a Versatile Cyber Physical Power System Testbed: Design and Operation Experience,” in *IEEE PES Innovative Smart Grid Technologies Europe (ISGT Europe), Espoo, Finland, 2021*, pp. 1-6, doi: 10.1109/ISGTEurope5232, 2021.
- [7] S. Sanchez-Acevedo and S. D’Arco, “A SDN Based Method for Blocking Malicious Attacks on Digital Substations Communication,” in *IEEE 5th International Conference on Industrial Cyber-Physical Systems (ICPS), Coventry, United Kingdom, 2022*, pp. 1-6, doi: 10.1109/ICPS51978.200.9816964, 2022.
- [8] S. Sanchez, S. Darco, N. Hurzuk and R. Løken, “Performance evaluation of intelligent electronic devices under stressed conditions,” in *IEEE PowerTech*, Madrid, 2021.
- [9] C. Espedal, N. Hurzuk and M. Istad, “Investigation of potential benefits of using extensive hotspot monitoring in power transformers,” in *6th International Colloquium on Transformer Research and Asset Management*, 2023.
- [10] S. Sanchez and S. Darco, “A SDN based method for blocking malicious attacks on digital substation communication,” in *IEEE 5th International Conference on Industrial Cyber-Physical Systems - ICPS*, 2022.
- [11] S. Y. Yayilgan, F. Holik, M. Abomhara, D. Abraham and A. Gebremedhin, “An approach for analyzing cyber security threats and attacks: A case study of digital substations in Norway,” *Electronics*, vol. 11, no. 23, 2022.
- [12] D. Abraham, S. Y. Yayilgan, M. Abomhara, A. Gebremedhin and F. Dalipi, “Security and Privacy issues in IoT based Smart Grids: A case study in a digital substation,” in *Holistic Approach for Decision Making Towards Designing Smart Cities*, Springer, 2022, pp. 57 - 74.
- [13] A. Khodabakhsh, S. Y. Yayilgan, M. Abomhara, M. K. Istad and N. Hurzuk, “Cyber-risk identification for a digital substation,” in *ARES '20: Proceedings of the 15th International Conference on Availability, Reliability and Security*, 2020.
- [14] A. Khodabakhsh, S. Y. Yayilgan, S. H. Houmb, N. Hurzuk, J. Foros and M. K. Istad, “Cyber-Security Gaps in a Digital Substation: From Sensors to SCADA,” in *2020 9th Mediterranean Conference on Embedded Computing (MECO)*, 2020.